

INSIGNIO

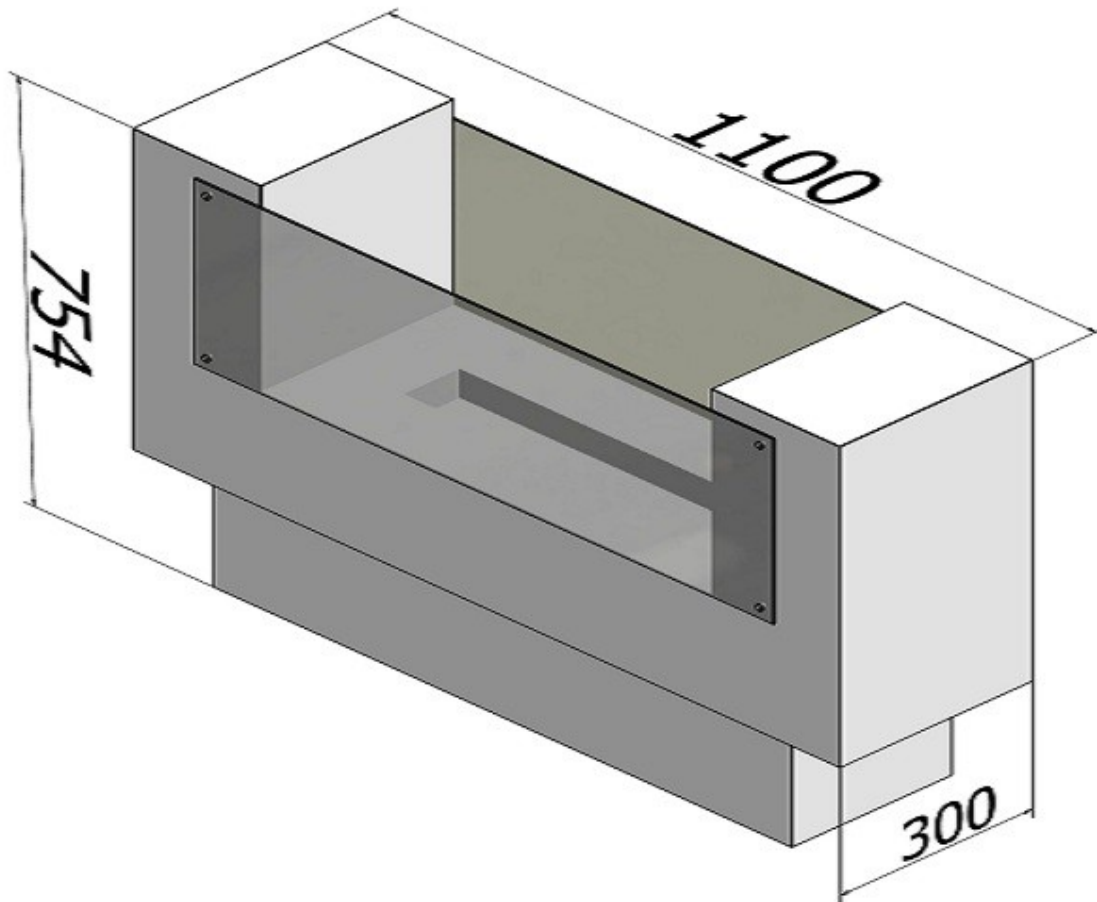

1. Technical description:

Color: BLACK semi matte/ WHITE semi matte + INOX

Size: 1100X750X300mm

Weight: 24kg

2. Components and kit:

Burner: 500mm, capacity 1,0 liter 4mm stainless steel INOX

Glass: 4mm tempered glass – tinted

3. Material:

Powder coated steel

Stainless steel INOX