

> GLOW FIRE

CW5
E-MOTION | WATER VAPOUR





Deutsch **WARNUNG:** Herabfallende Möbel können schwere oder lebensgefährliche Verletzungen verursachen. Das Möbelstück muss an der Wand befestigt werden. Befestigungsmaterial ist nicht enthalten. Verwenden Sie geeignete Schrauben und Dübel entsprechend dem Wandmaterial und holen Sie bei Unsicherheit fachlichen Rat ein. Montageanleitung sorgfältig befolgen.

Achtung: Nicht für Kinder unter 3 Jahren geeignet – Erststückerkrankung durch Kleinteile.
Pflege: Mit feuchtem Tuch reinigen, anschließend trocken nachwischen. Montage-etiketten erst nach vollständiger Montage und bei Behalten des Möbelstücks entfernen.

English **WARNING:** Falling furniture can cause serious or fatal injuries. The furniture must be secured to the wall. Fixing materials are not included. Use suitable screws and wall plugs according to the wall type and seek professional advice if unsure. Follow the assembly instructions carefully.

Caution: Not suitable for children under 3 years – choking hazard due to small parts.

Care: Clean with a damp cloth, then wipe dry. Remove assembly labels only after complete assembly and if the furniture is to be kept.

Français **AVERTISSEMENT:** La chute de meubles peut provoquer des blessures graves ou mortelles. Le meuble doit être fixé au mur. Le matériel de fixation n'est pas fourni. Utilisez des vis et chevilles adaptées au type de mur et demandez conseil à un professionnel en cas de doute. Suivez attentivement les instructions de montage.

Attention: Ne convient pas aux enfants de moins de 3 ans – risque d'étouffement dû aux petites pièces.

Entretien: Nettoyer avec un chiffon humide puis essuyer avec un chiffon sec. Retirer les étiquettes de montage uniquement après l'assemblage complet et si le meuble est conservé.

Dansk **ADVARSEL:** Nedfaldende møbler kan forårsage alvorlige eller livsfarlige skader. Møblen skal fastgøres til væggen. Befæstelsesmateriale medfølger ikke. Brug passende skruer og vægplugs til vægtypen, og søg faglig rådgivning ved tvivl. Følg samlevejledningen nøje.

Advarsel: Ikke egnet til børn under 3 år – kvælningfare på grund af små dele.

Pleje: Rengør med en fugtig klud og tør efter med en tør klud. Fjern monteringsetiketterne først efter fuld montering og hvis møblen beholdes.

Espanol **ADVERTENCIA:** La caída de muebles puede causar lesiones graves o mortales. El mueble debe fijarse a la pared. El material de fijación no está incluido. Utilice tornillos y tacos adecuados al tipo de pared y consulte a un profesional en caso de duda. Siga cuidadosamente las instrucciones de montaje.

Atención: No apto para niños menores de 3 años – peligro de asfixia por piezas pequeñas.

Cuidado: Limpiar con un paño húmedo y secar con un paño seco. Retirar las etiquetas de montaje solo después del montaje completo y si se conserva el mueble.

Italiano **AVVERTENZA:** La caduta dei mobili può causare lesioni gravi o mortali. Il mobile deve essere fissato alla parete. Il materiale di fissaggio non è incluso. Utilizzare viti e tasselli adatti al tipo di parete e, in caso di dubbi, consultare un professionista. Seguire attentamente le istruzioni di montaggio.

Attenzione: Non adatto ai bambini di età inferiore ai 3 anni – pericolo di soffocamento a causa di piccole parti.

Cura: Pulire con un panno umido e asciugare con un panno asciutto. Rimuovere le etichette di montaggio solo dopo il montaggio completo e se il mobile viene conservato.

Nederlands **WAARSCHUWING:** Omvallende meubels kunnen ernstig of dodelijk letsel veroorzaken. Het meubel moet aan de muur worden bevestigd. Bevestigingsmateriaal is niet inbegrepen. Gebruik geschikte schroeven en pluggen voor het type muur en raadpleeg bij twijfel een vakman. Volg de montage-instructies zorgvuldig.

Let op: Niet geschikt voor kinderen jonger dan 3 jaar – verstikkingsgevaar door kleine onderdelen.

Onderhoud: Reinigen met een vochtige doek en nadrogen met een droge doek. Verwijder montage-etiketten pas na volledige montage en als het meubel wordt behouden.

Polski **OSTRZEŻENIE:** Spadające meble mogą spowodować poważne lub śmiertelne obrażenia. Mebel musi być przymocowany do ściany. Elementy montażowe nie są dołączone. Używaj śrub i kołków odpowiednich do rodzaju ściany, a w razie wątpliwości skonsultuj się ze specjalistą. Dokładnie przestrzegaj instrukcji montażu.

Uwaga: Nieodpowiednie dla dzieci poniżej 3 lat – ryzyko zadławienia małymi elementami.

Pielęgnacja: Czyścić wilgotną ściereczką, a następnie wytrzeć do sucha. Usunąć etykiety montażowe dopiero po całkowitym montażu i jeśli mebel ma zostać zachowany.

Portugues **AVISO:** A queda de móveis pode causar ferimentos graves ou fatais. O móvel deve ser fixado à parede. O material de fixação não está incluído. Utilize parafusos e buchas adequados ao tipo de parede e procure aconselhamento profissional em caso de dúvida. Siga cuidadosamente as instruções de montagem.

Atenção: Não adequado para crianças com menos de 3 anos – risco de asfixia devido a peças pequenas.

Cuidados: Limpar com um pano húmido e secar com um pano seco. Remover as etiquetas de montagem apenas após a montagem completa e se o móvel for mantido.

Русский **ПРЕДУПРЕЖДЕНИЕ:** Падающая мебель может привести к серьёзным или смертельным травмам. Мебель необходимо закрепить на стене. Крепёжные элементы не входят в комплект. Используйте подходящие винты и дюбели в зависимости от типа стены и при сомнениях обращайтесь к специалисту. Внимательно следуйте инструкции по сборке.

Внимание: Не подходит для детей младше 3 лет — опасность удушья из-за мелких деталей.

Уход: Протирать влажной тканью, затем вытирать насухо. Удалять монтажные этикетки только после полной сборки и если мебель остаётся в использовании.

Für Brett-Nachbestellungen geben Sie bitte die unten stehende Etikett-Nummer an und senden bei beschädigten Brettern ein Foto mit.

For board reorders, please provide the label number below and send a photo of damaged boards.

Pour toute commande supplémentaire de planches, veuillez indiquer le numéro d'étiquette ci-dessous et joindre une photo des planches endommagées.

Ved genbestilling af brædder bedes du angive nedenstående etiketnummer og vedlægge et foto af beskadigede brædder.

Para realizar pedidos adicionales de tablas, indique el número de etiqueta que aparece a continuación y, en caso de tablas dañadas, envíe una foto.

Per riordinare le tavole, indicare il numero di etichetta riportato di seguito e, in caso di tavole danneggiate, allegare una foto.

Voor nabestelling van planken dient u het onderstaande etiketnummer te vermelden en bij beschadigde planken een foto mee te sturen.

W przypadku ponownego zamawiania desek prosimy podać poniższy numer etykiety, a w przypadku uszkodzonych desek prosimy o przesłanie zdjęcia.

Para encomendas posteriores, indique o número indicado na etiqueta abaixo.

Для повторного заказа досок укажите номер этикетки, указанный ниже, а в случае повреждения досок приложите фотографию.

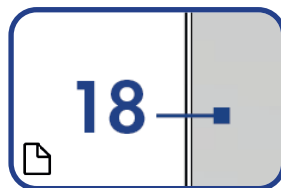
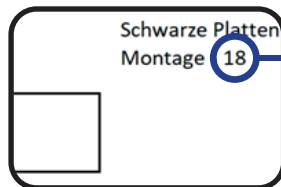
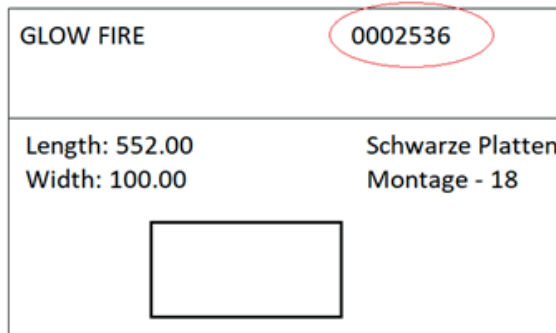

Diese Nummer auf dem Etikett entspricht der Brettnummer in der Aufbauanleitung.

This number on the label corresponds to the board number in the assembly instructions.

Ce numéro sur l'étiquette correspond au numéro de planche dans les instructions de montage.

Dette nummer på etiketten svarer til bræddenummeret i monteringsvejledningen.

Este número en la etiqueta corresponde al número de tablero en las instrucciones de montaje.

Questo numero sull'etichetta corrisponde al numero della tavola riportato nelle istruzioni di montaggio.

Numer ten na etykietce odpowiada numerowi deski w instrukcji montażu.

See number etiketil vastab ehitusjuhendis olevale lava numbrile.

Este número na etiqueta corresponde ao número da placa nas instruções de montagem.

Этот номер на этикетке соответствует номеру доски в инструкции по сборке.

A címkén szereplő szám megegyezik a szerelési útmutatóban szereplő deszkaszámmal.



Glow Fire GmbH
Lilienthalstraße 10, 15344 Strausberg

Eingetragen beim Amtsgericht Frankfurt (Oder)
HRB 20198 FF | WEEE-Nr. DE 67732298
glow-fire.com

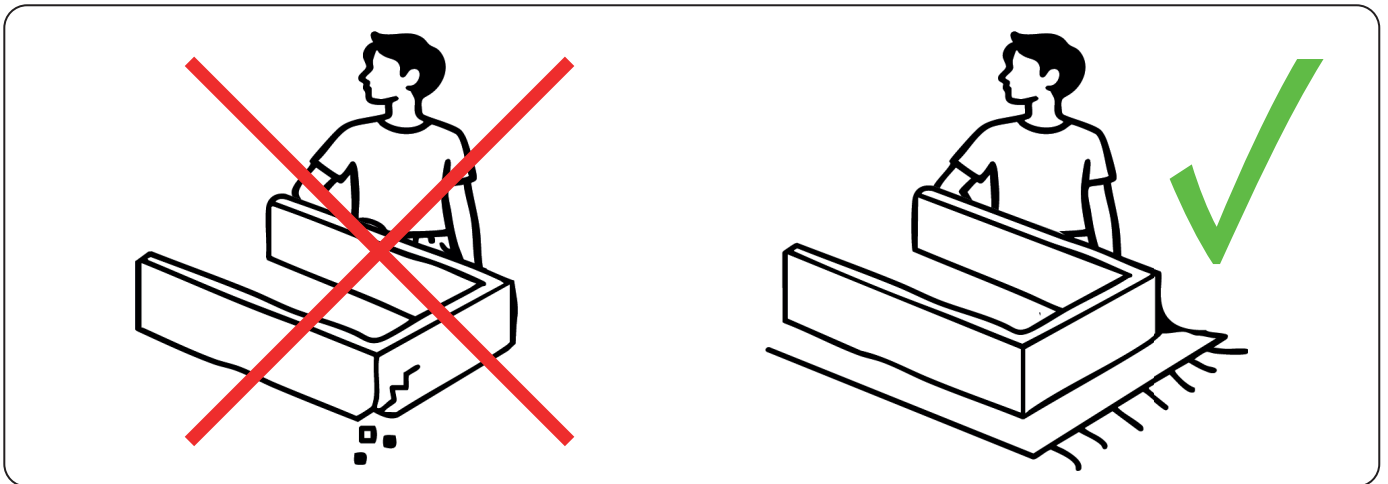
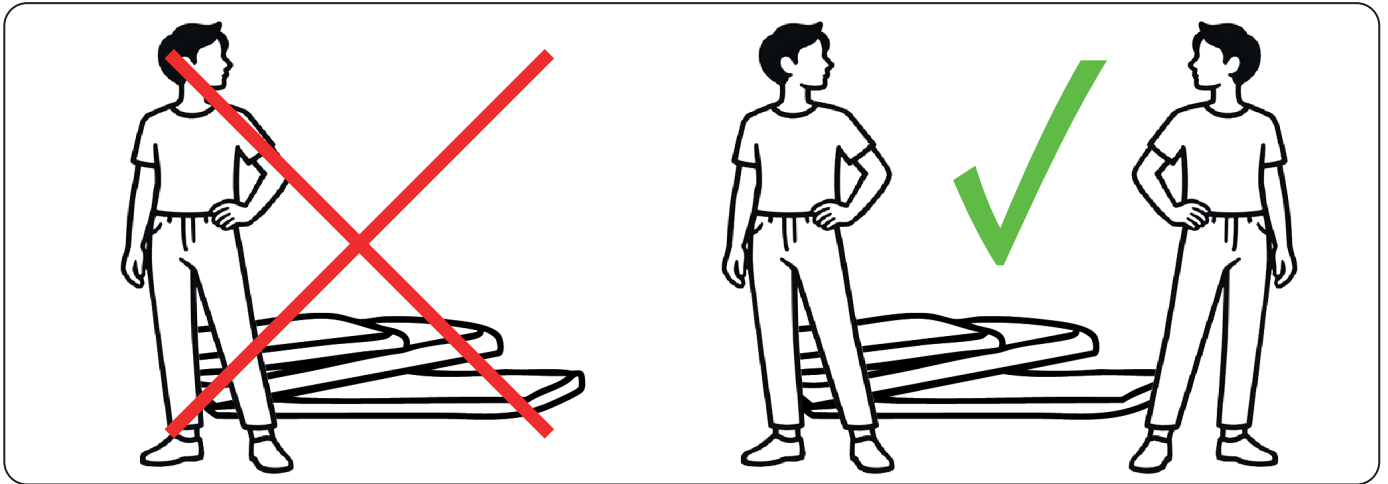
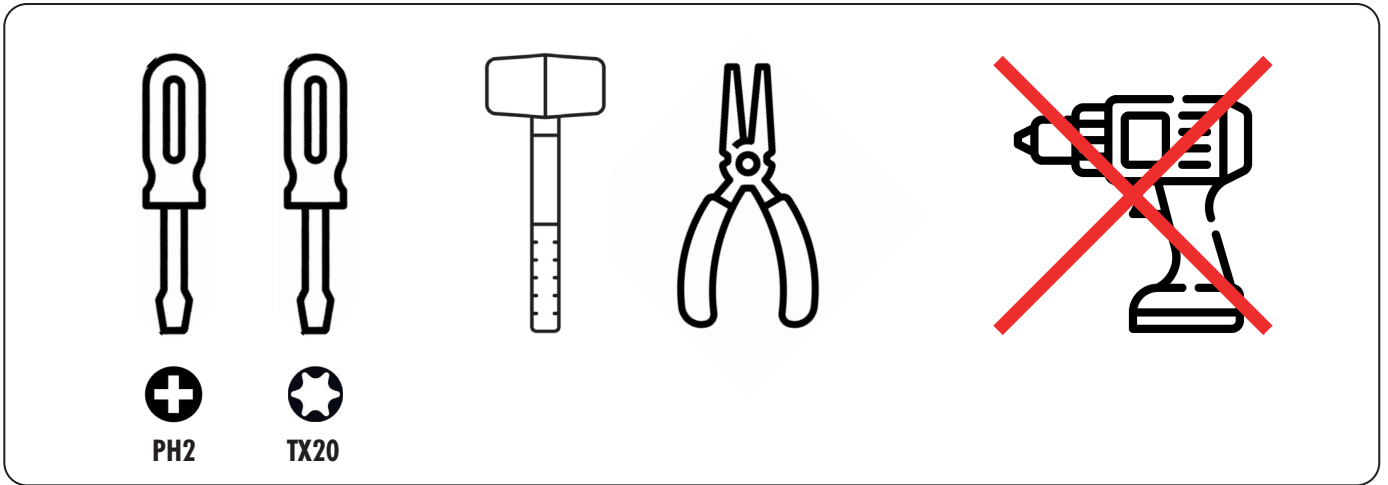

Cabineo

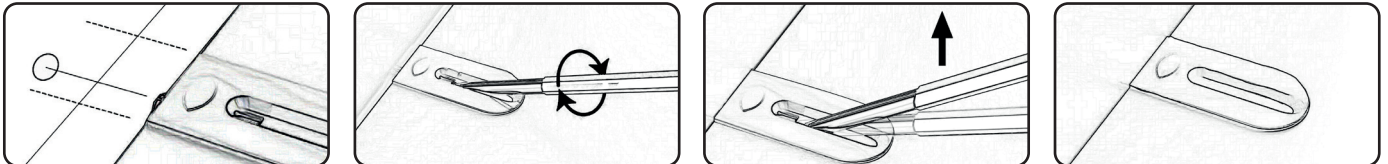

Tip-On

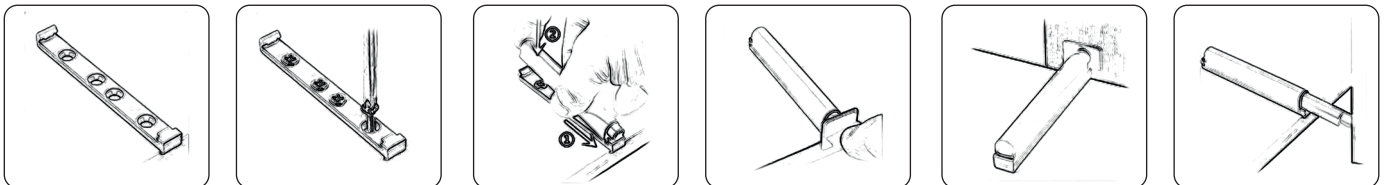

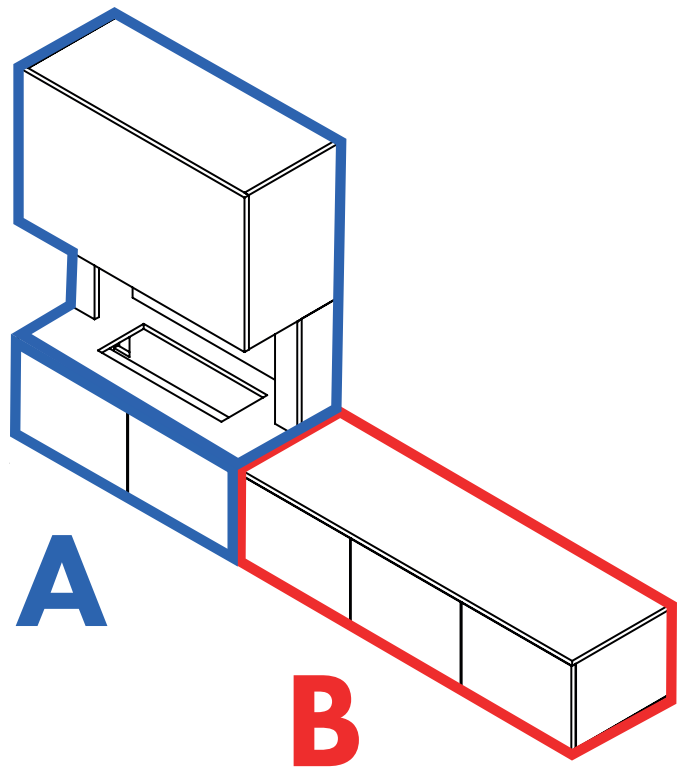
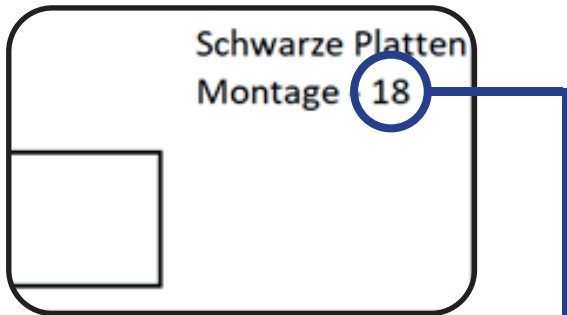
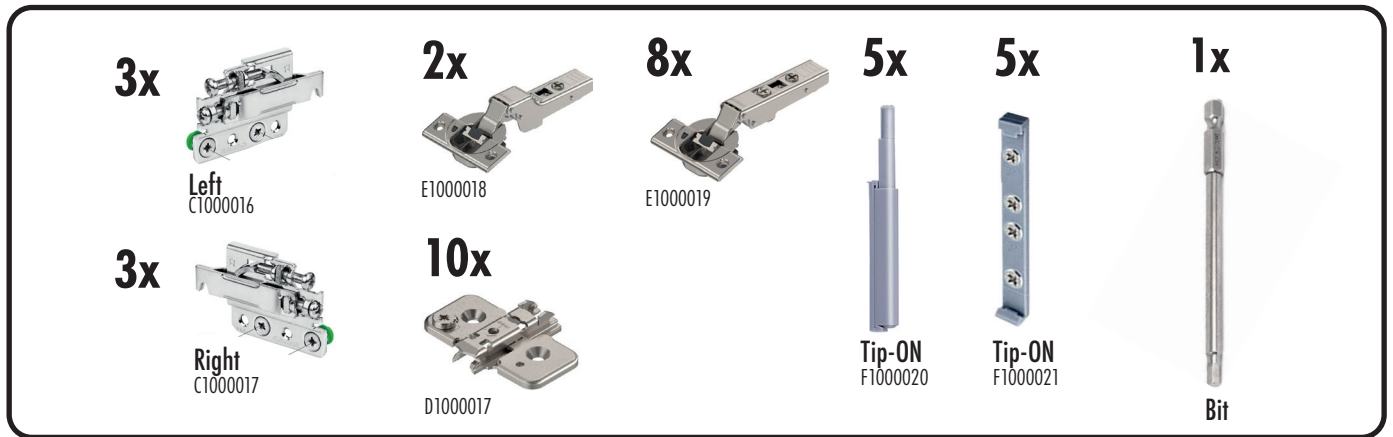
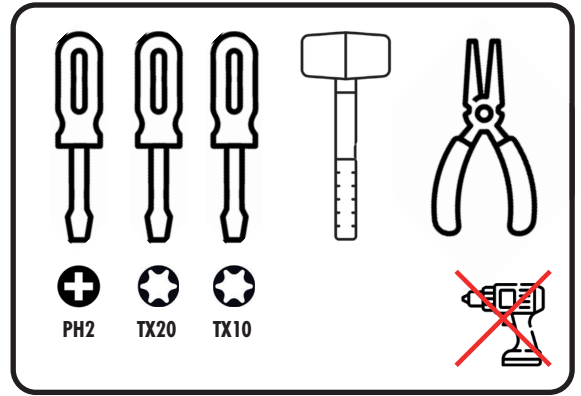
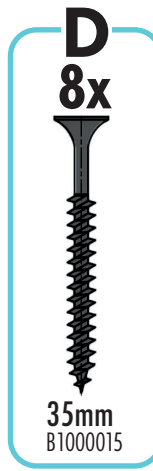
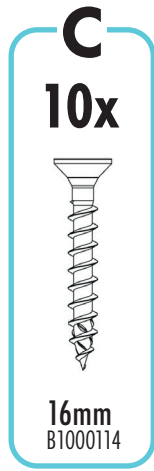
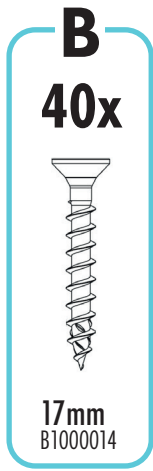
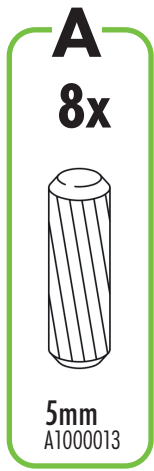

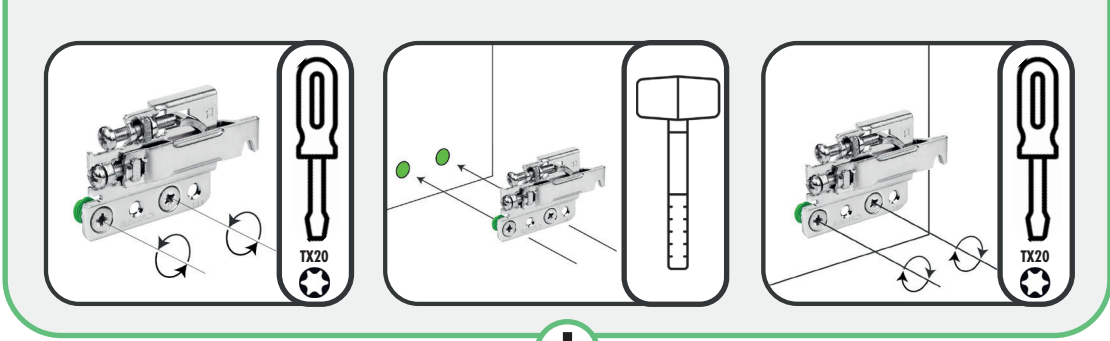

1

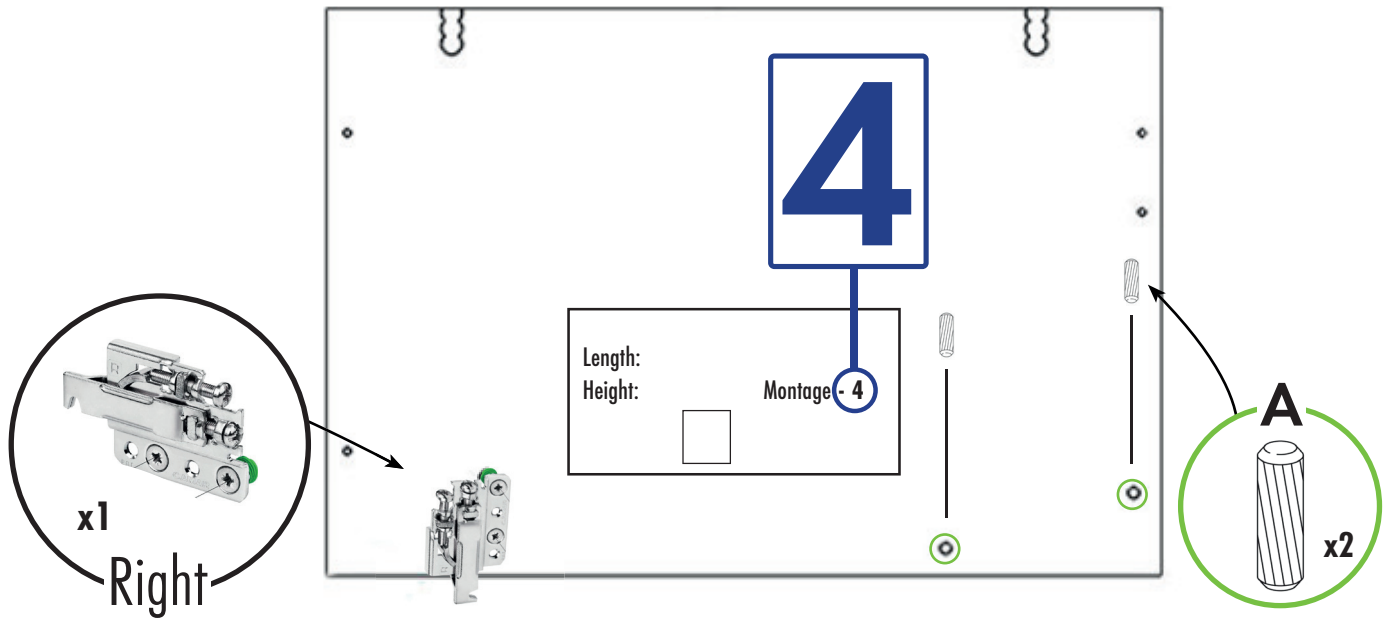

2

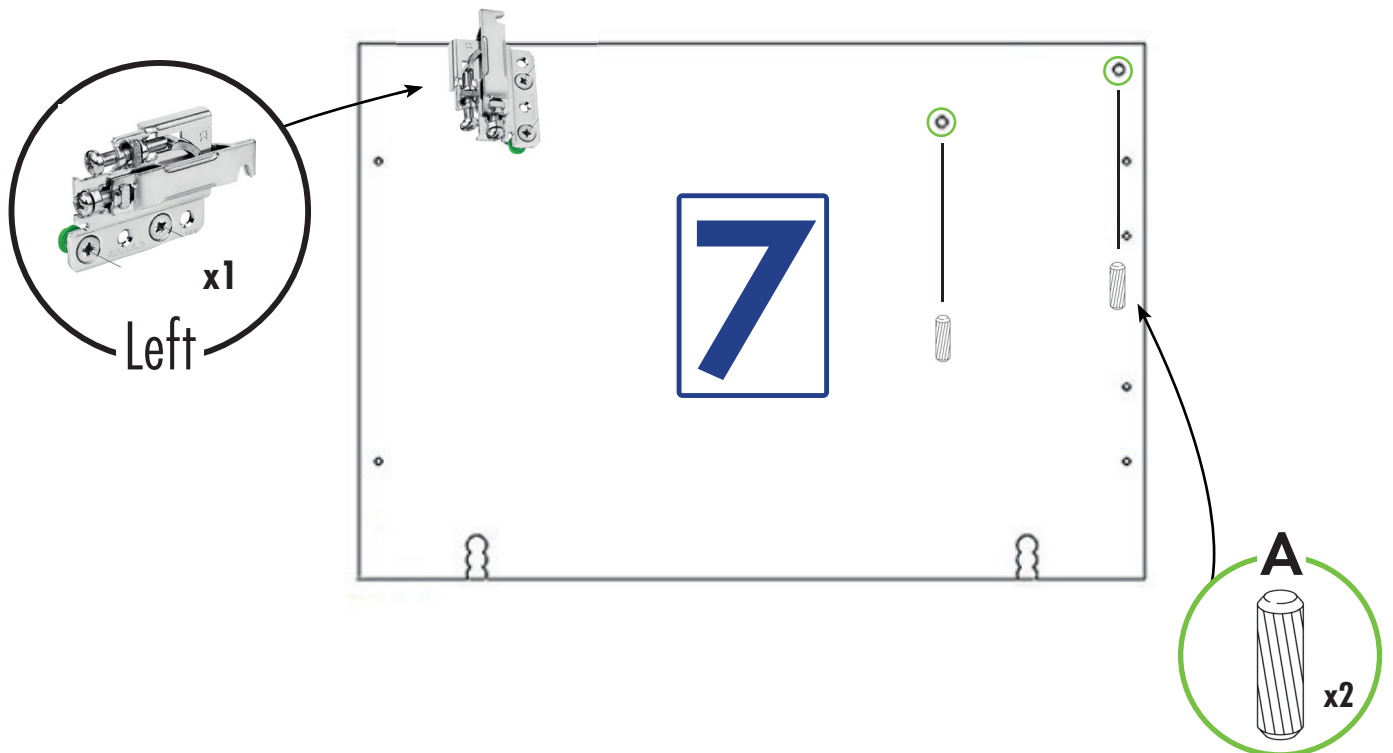

3

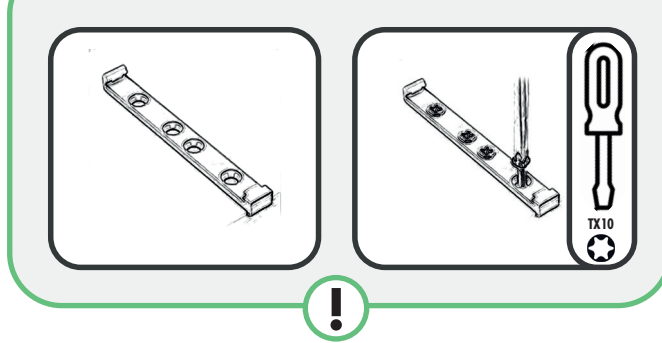

A

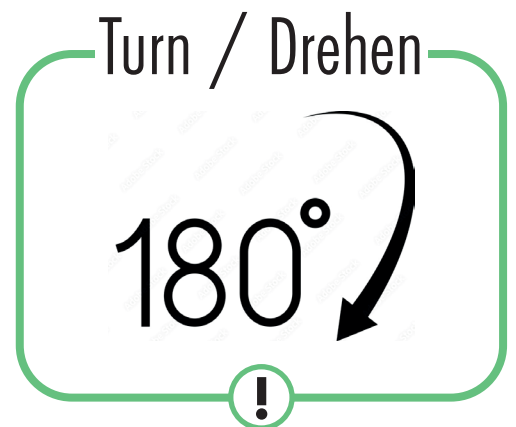
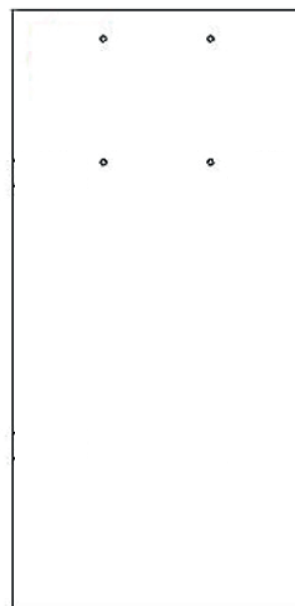
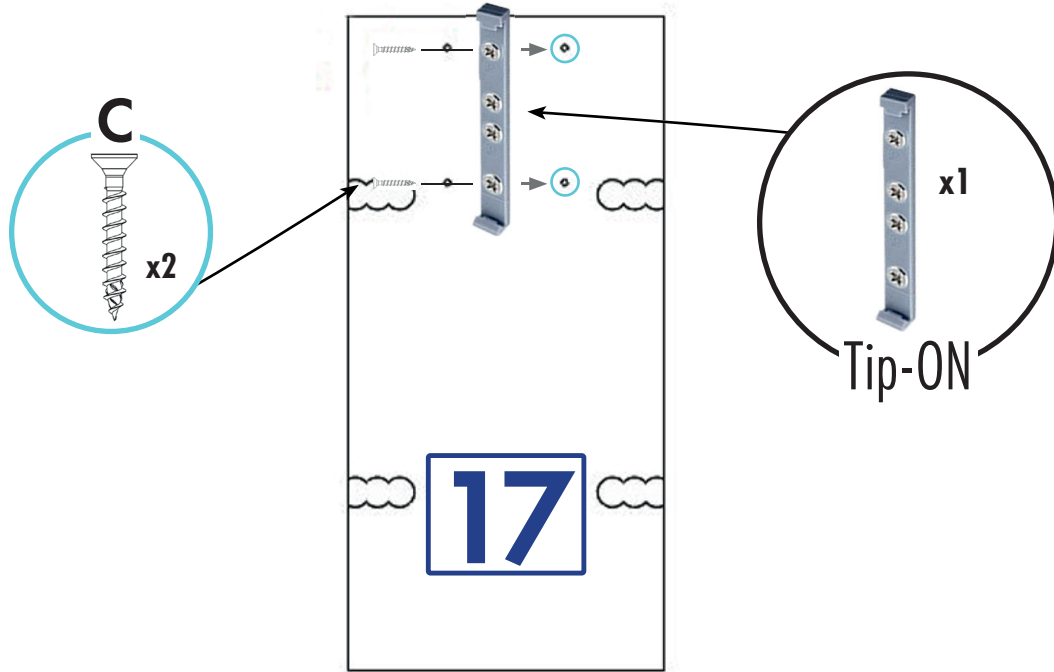

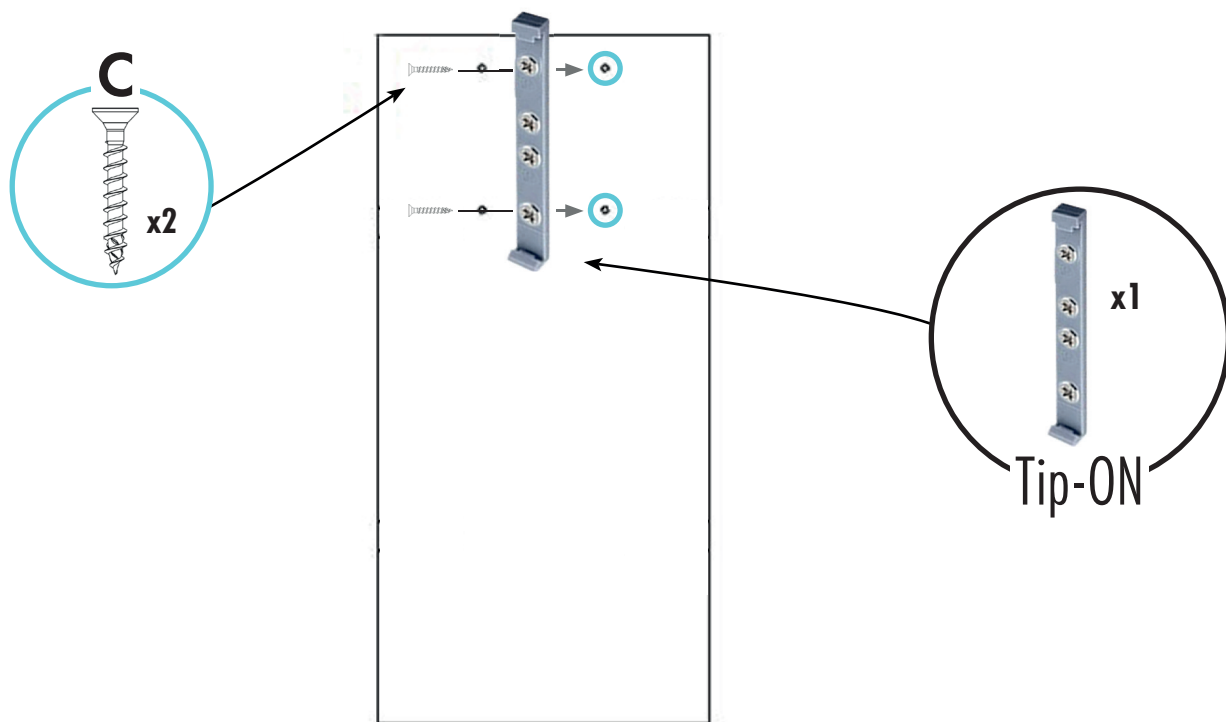

4

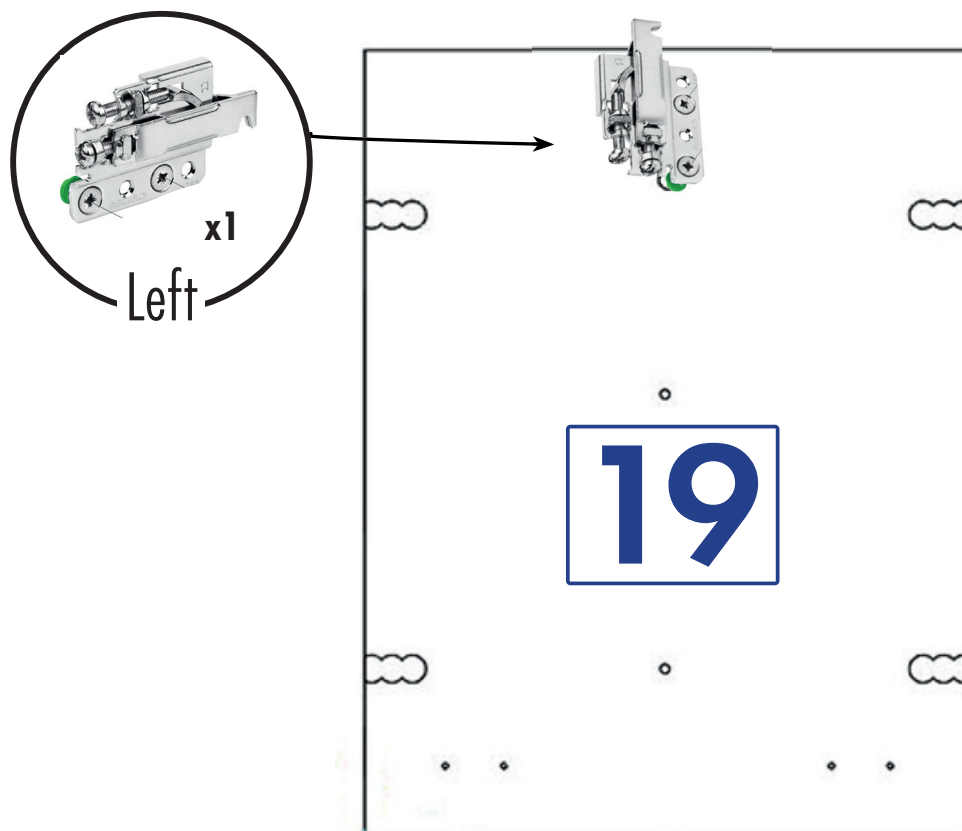

A

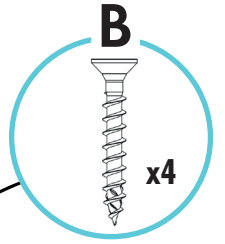
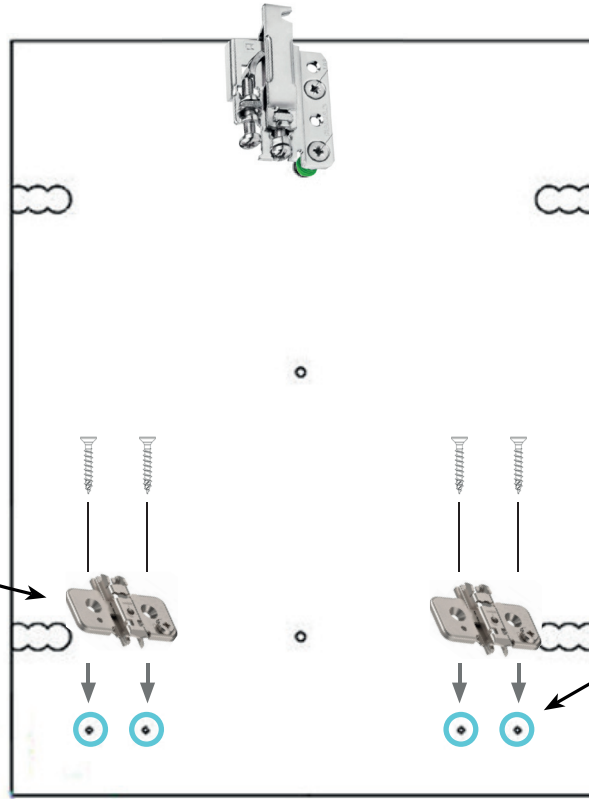
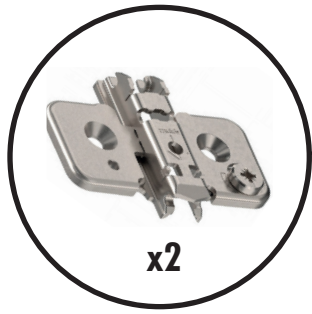
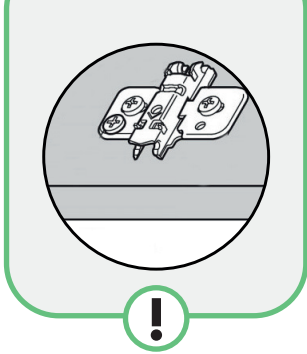

5

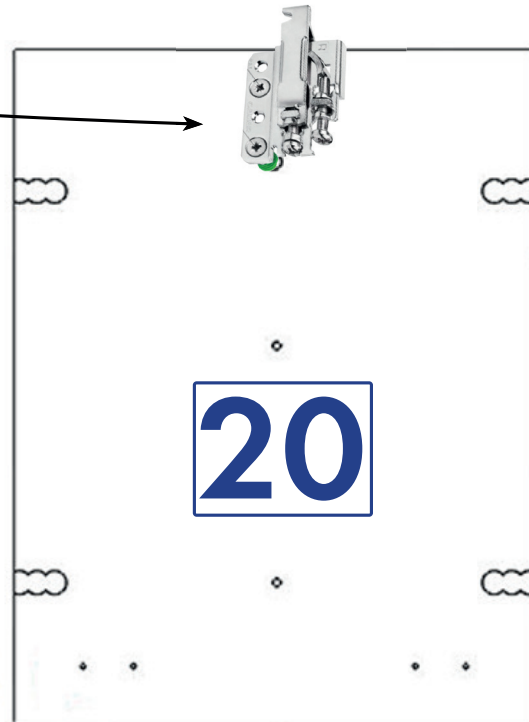
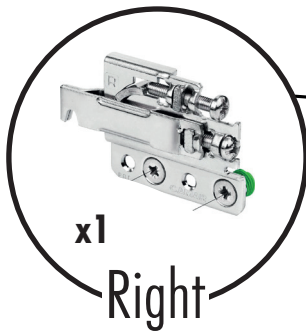

A

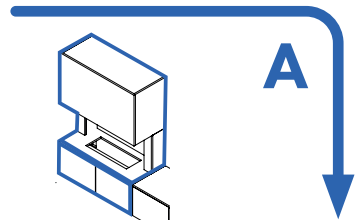
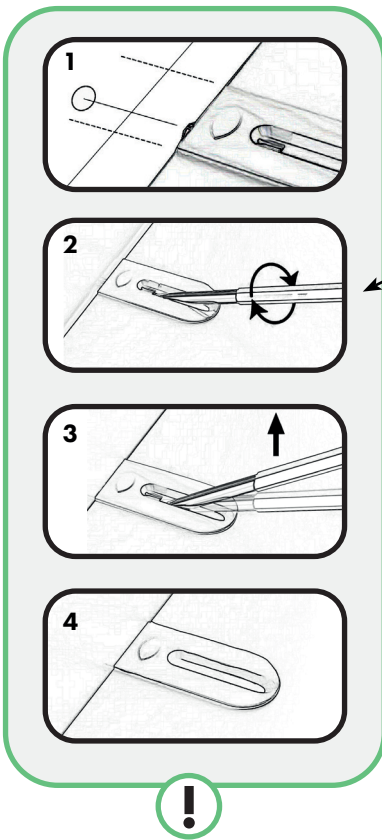
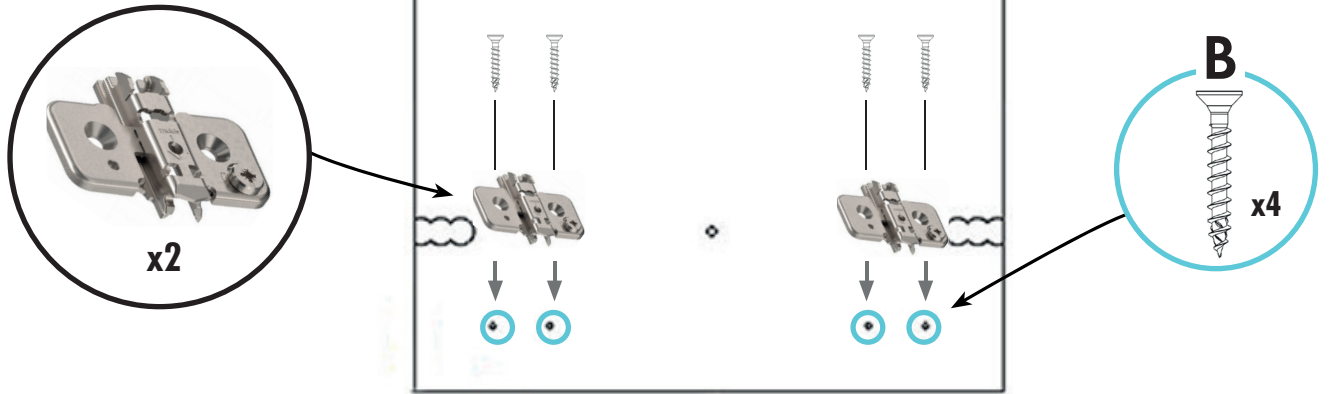

6

16

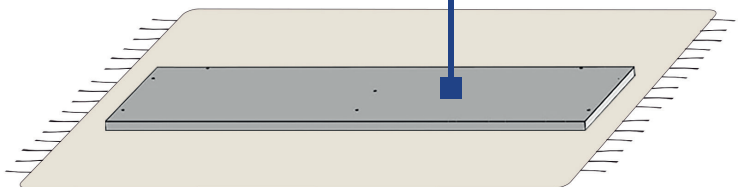

7

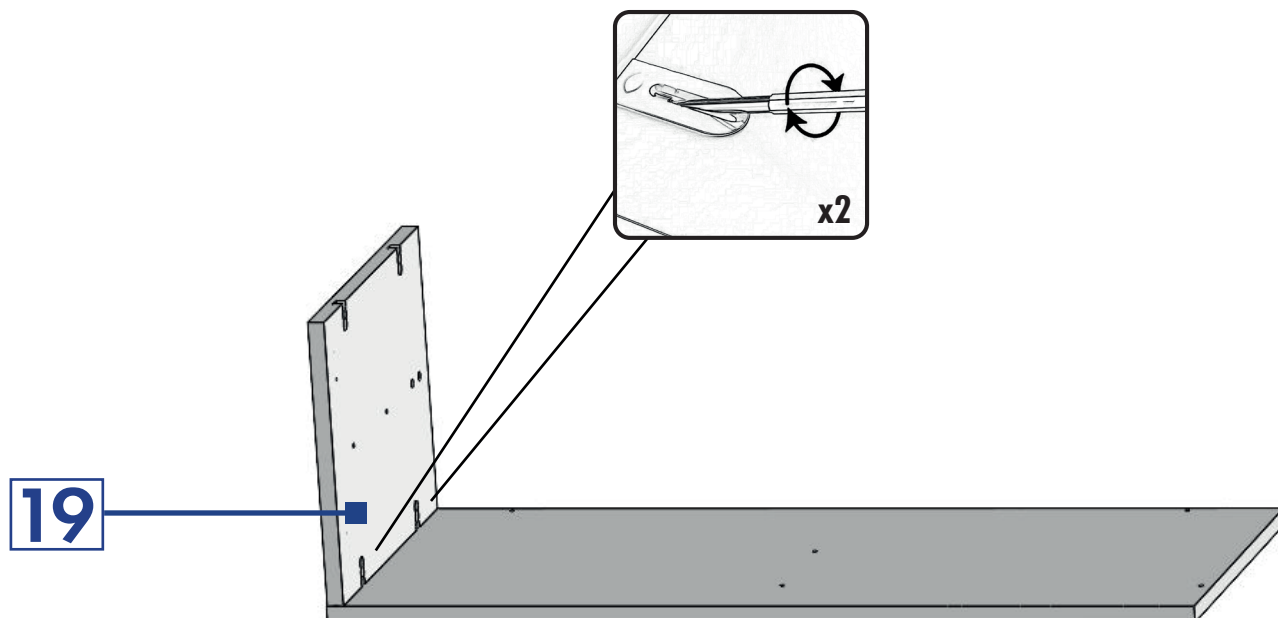

8

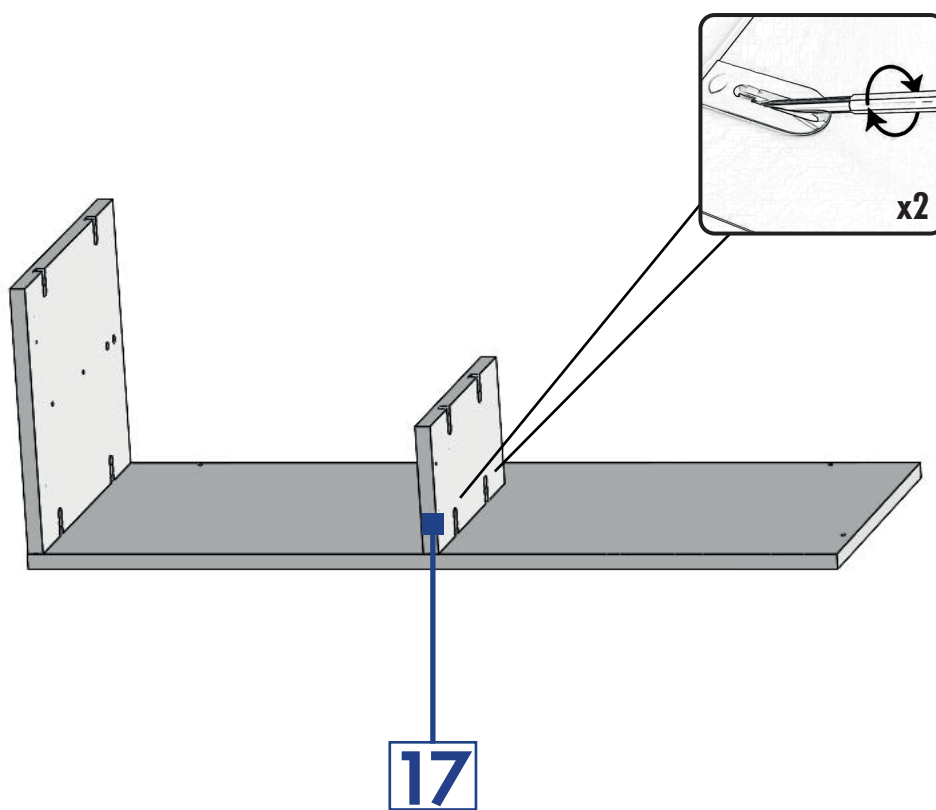

9

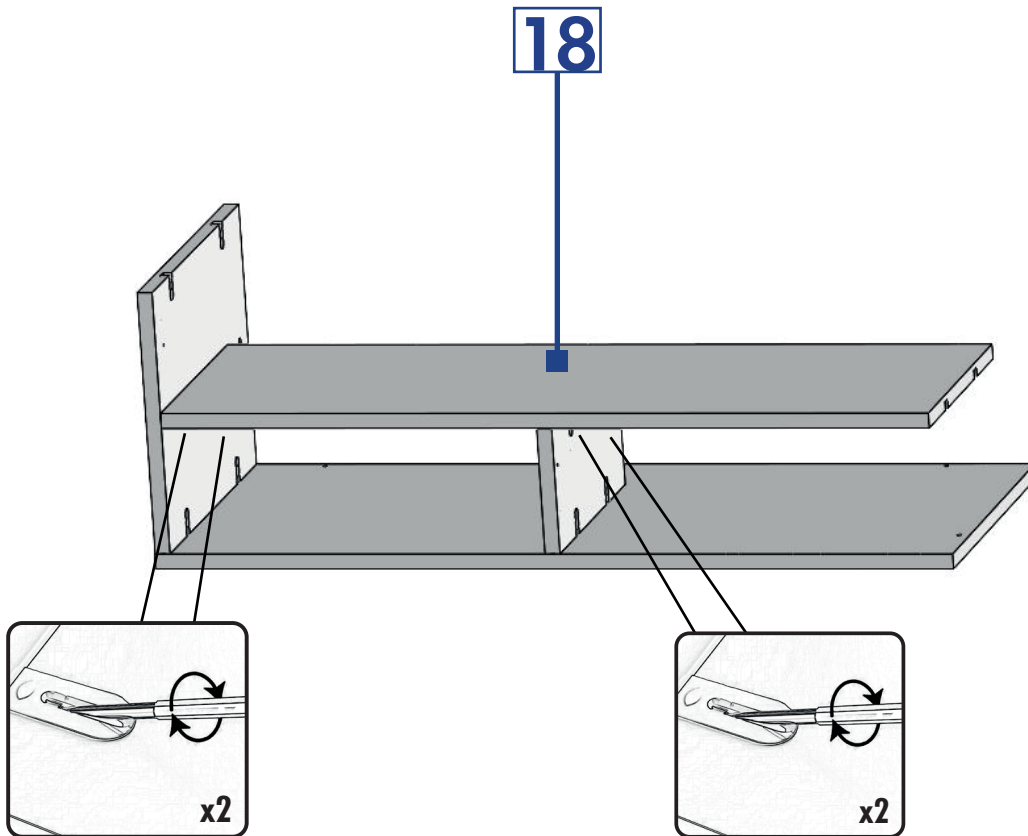

10

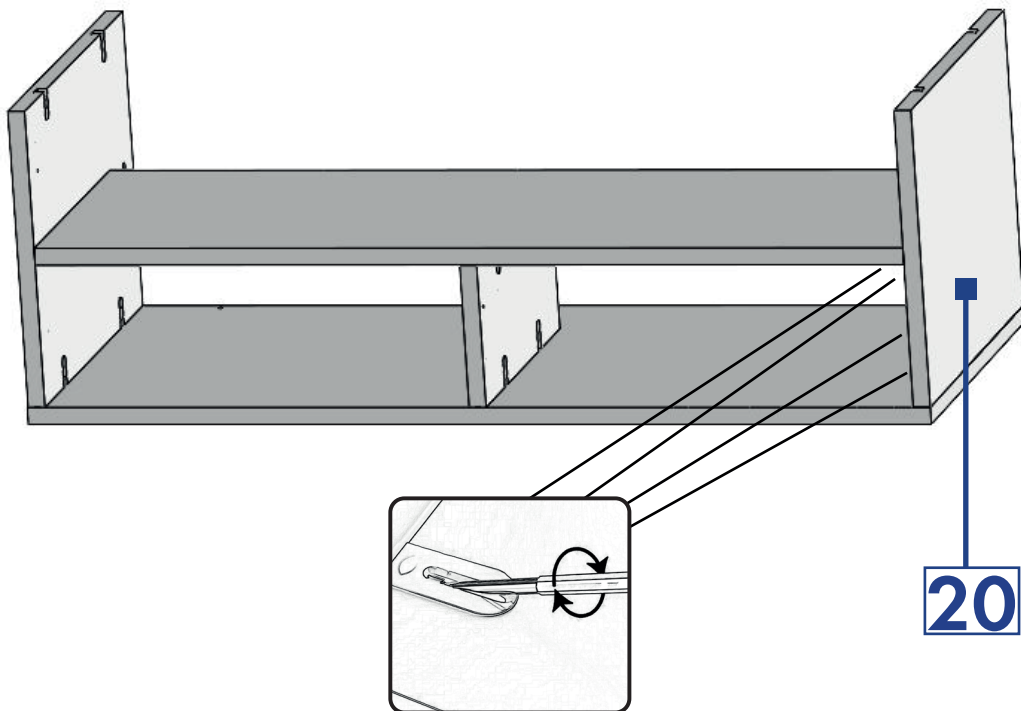

11

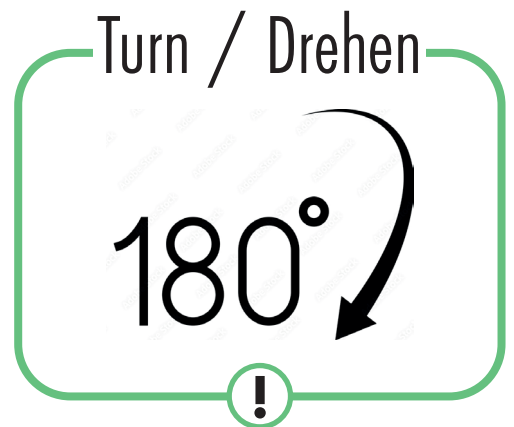
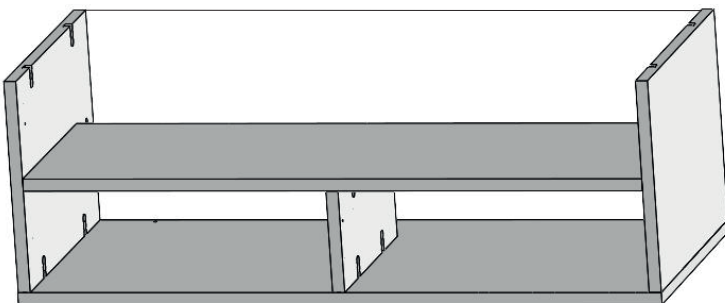
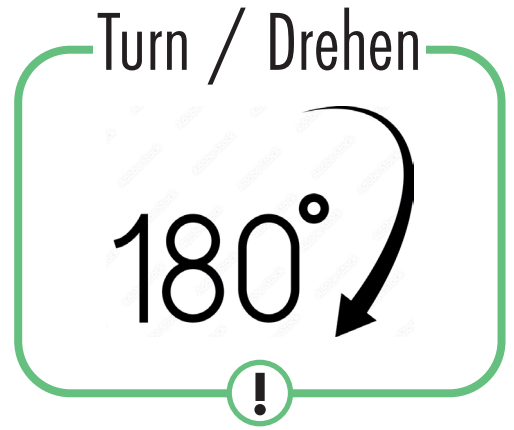
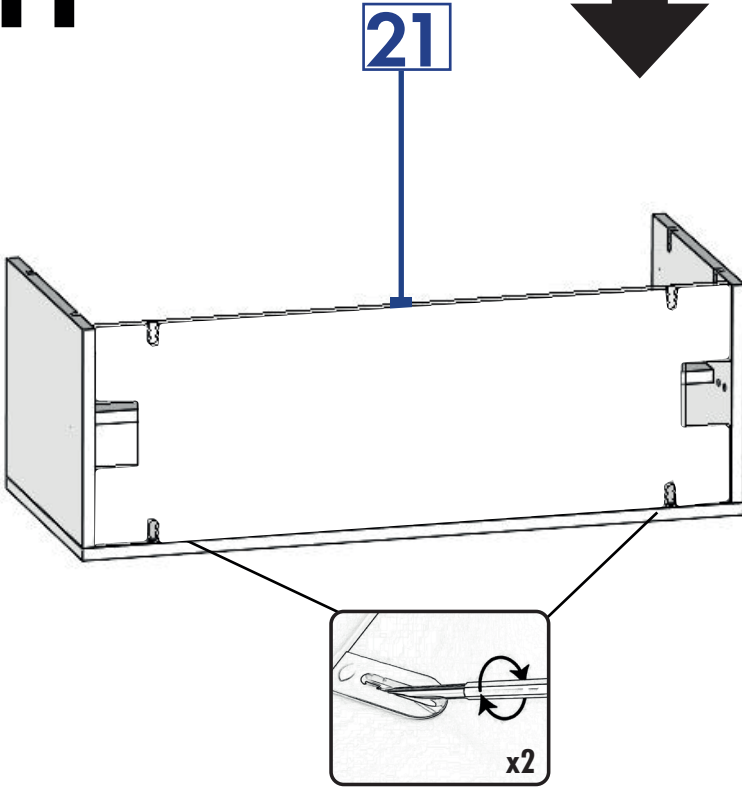

12

A

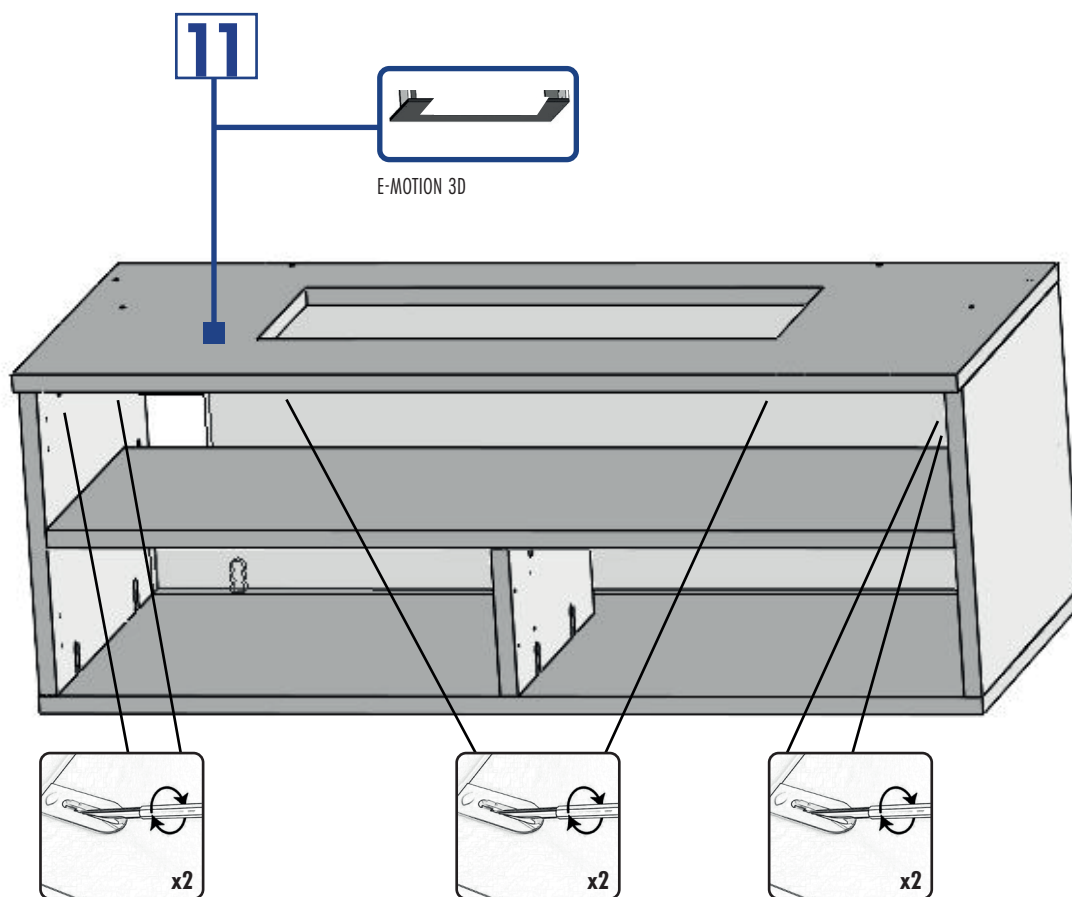

13

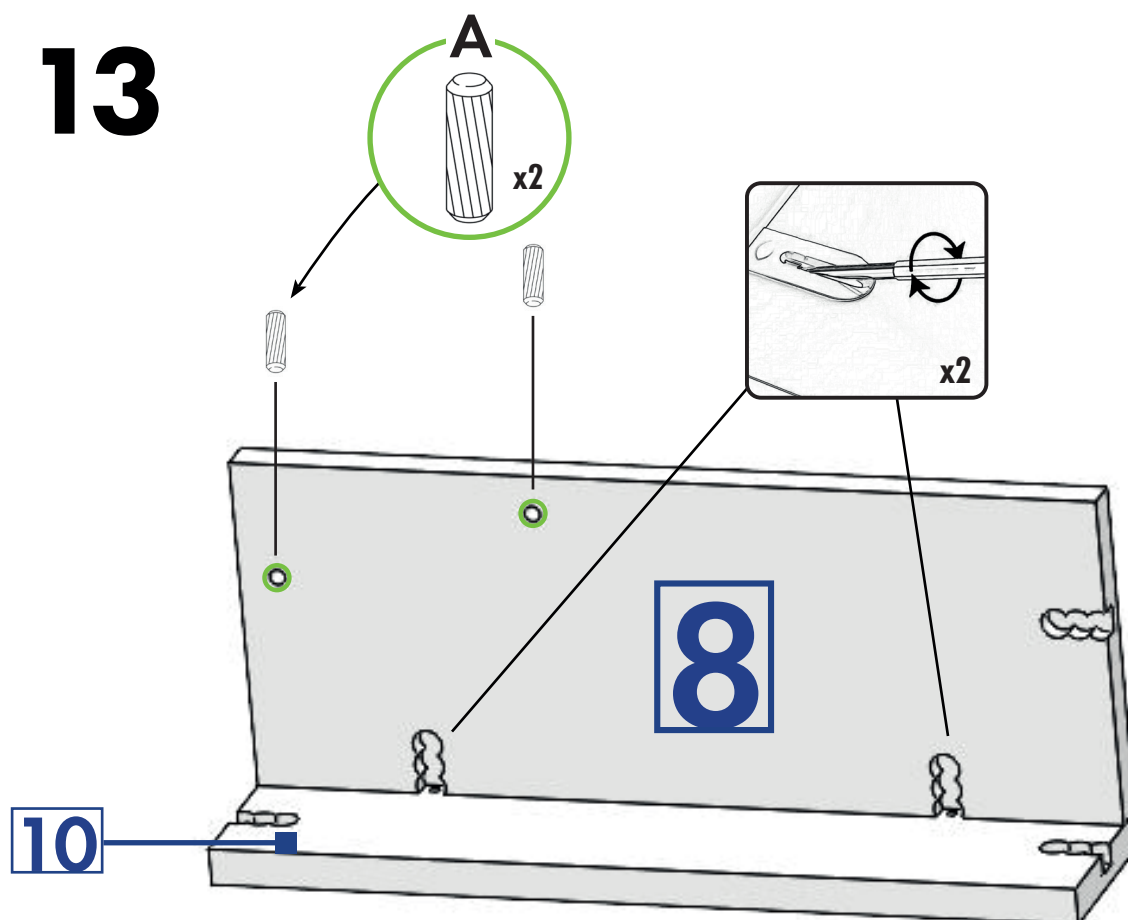

14

A

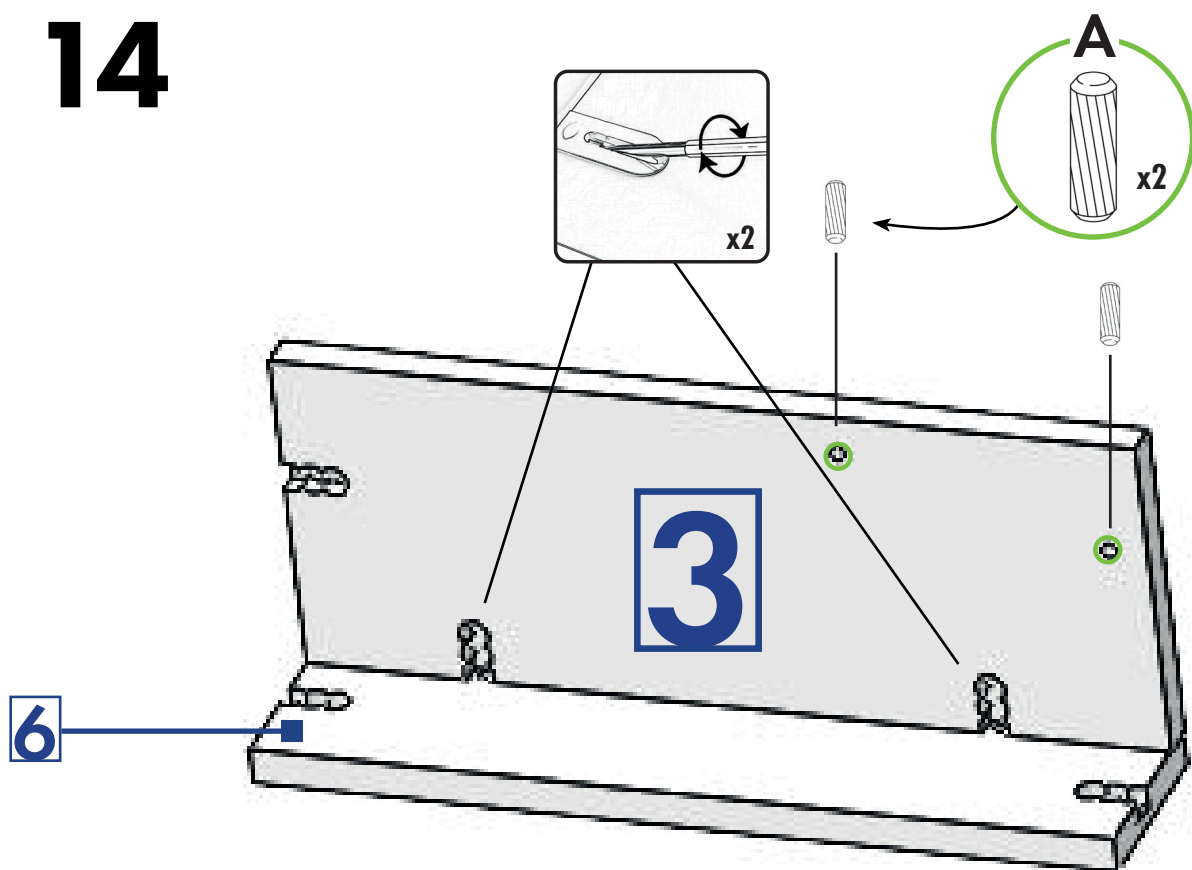

15

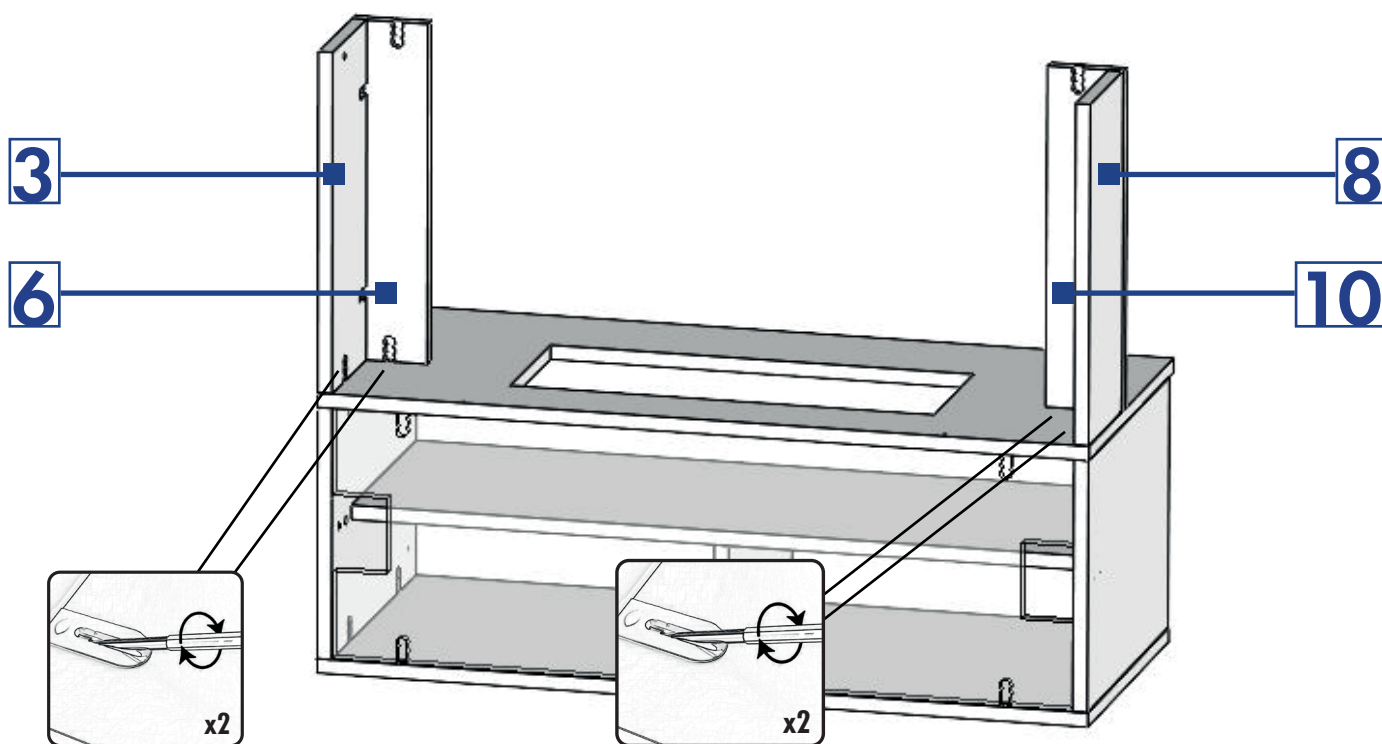

16

A

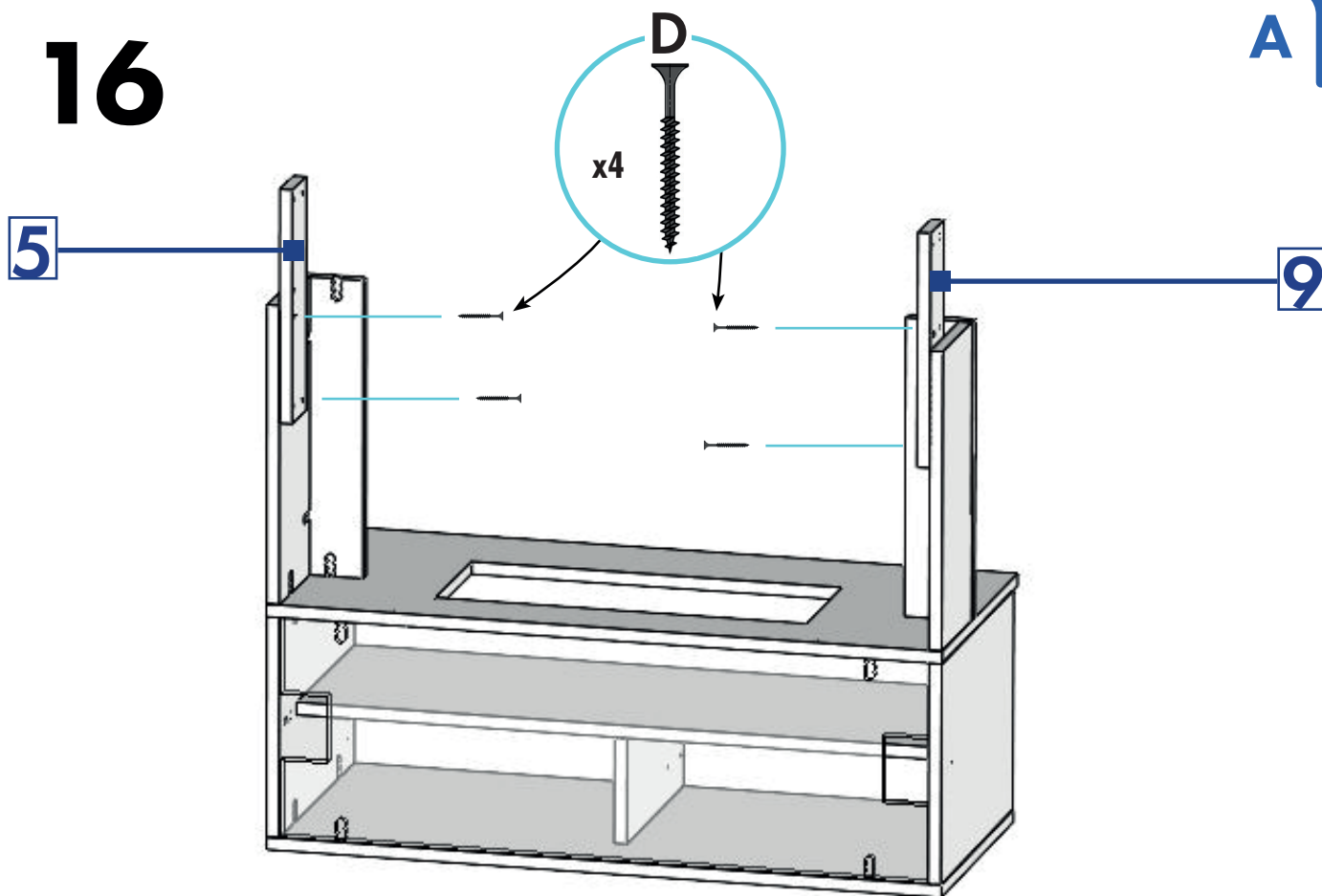

17

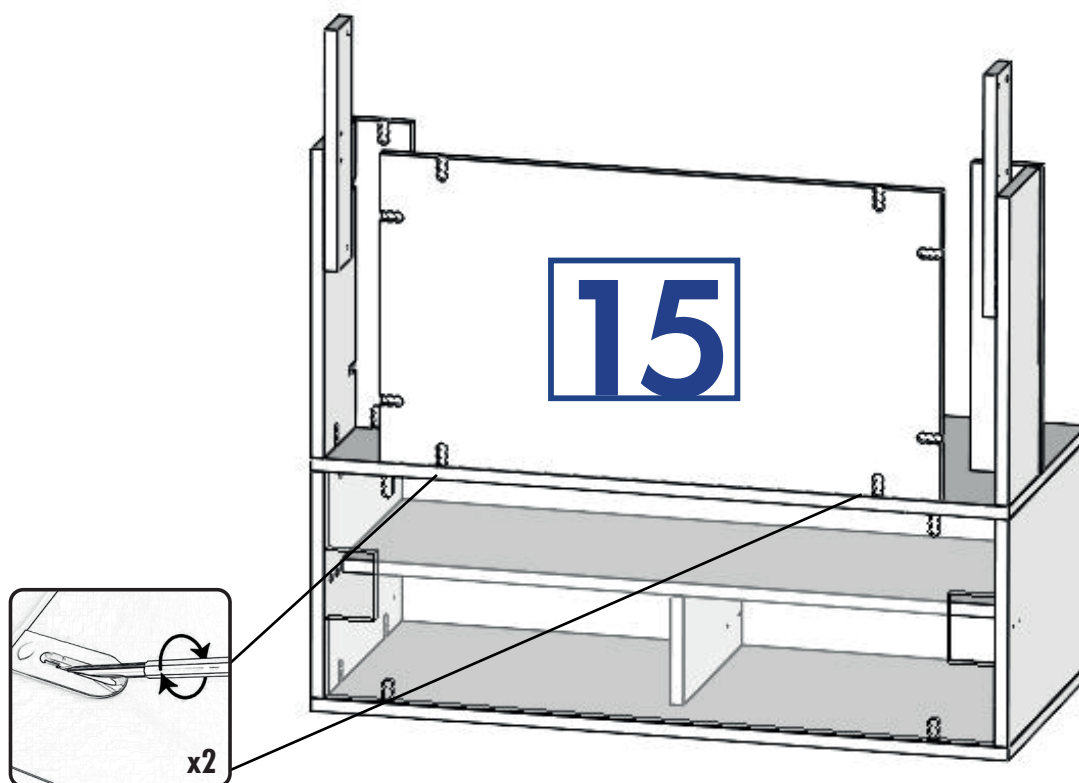

18

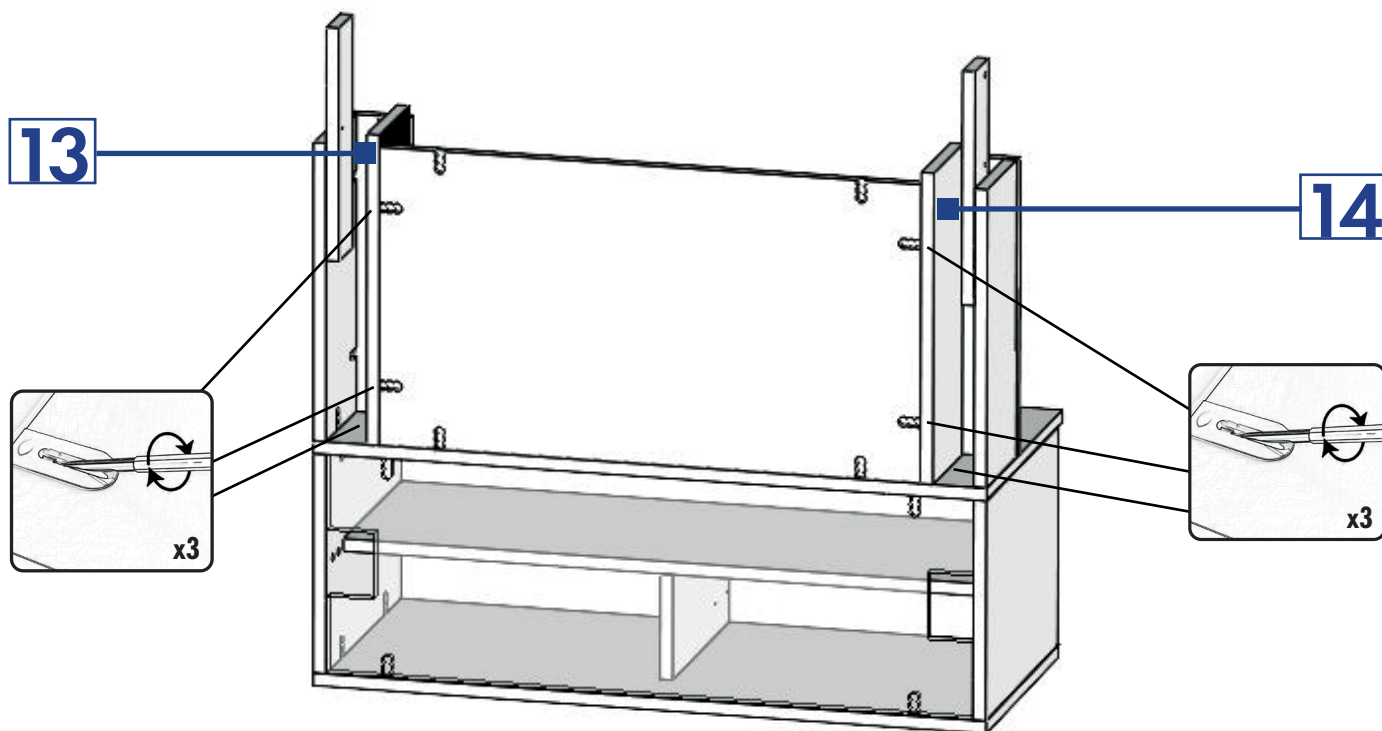

19

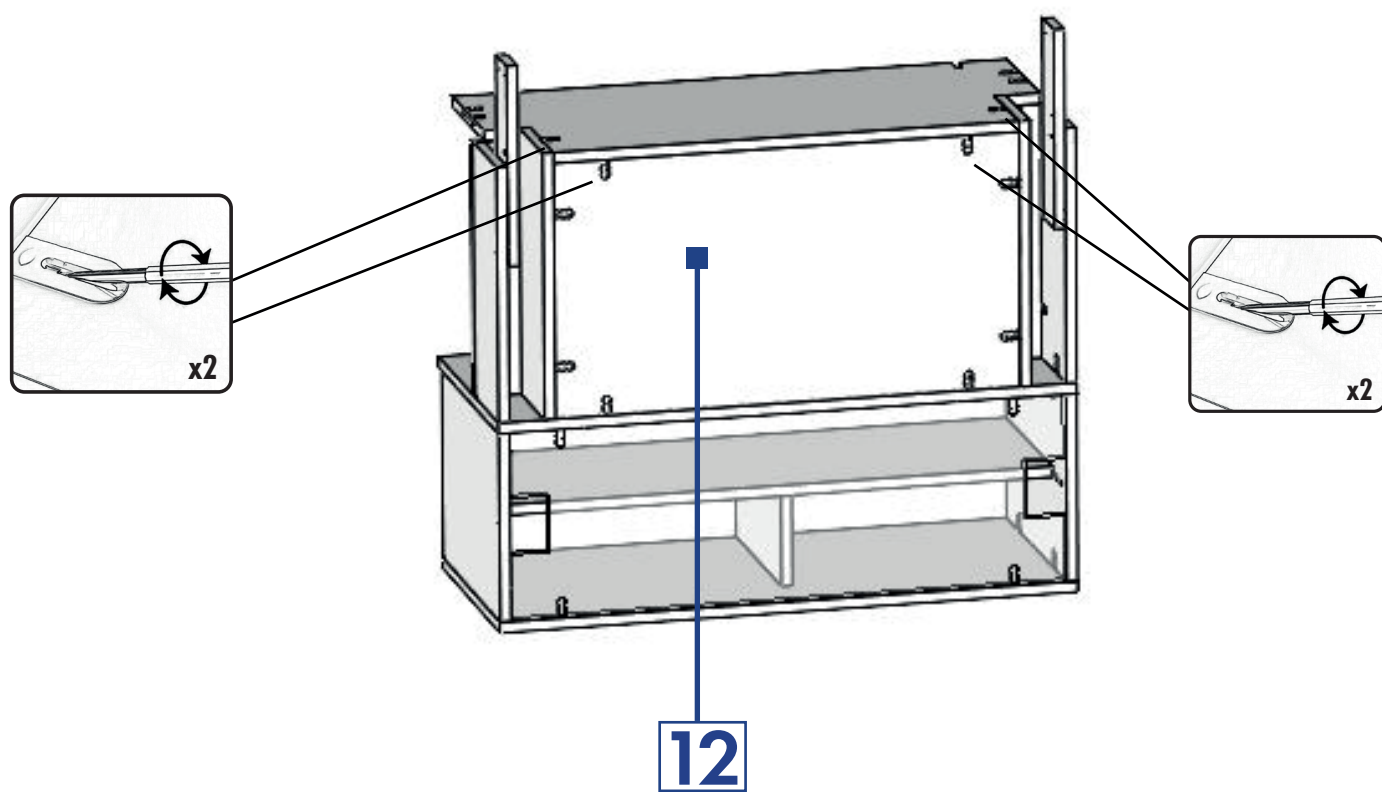

20

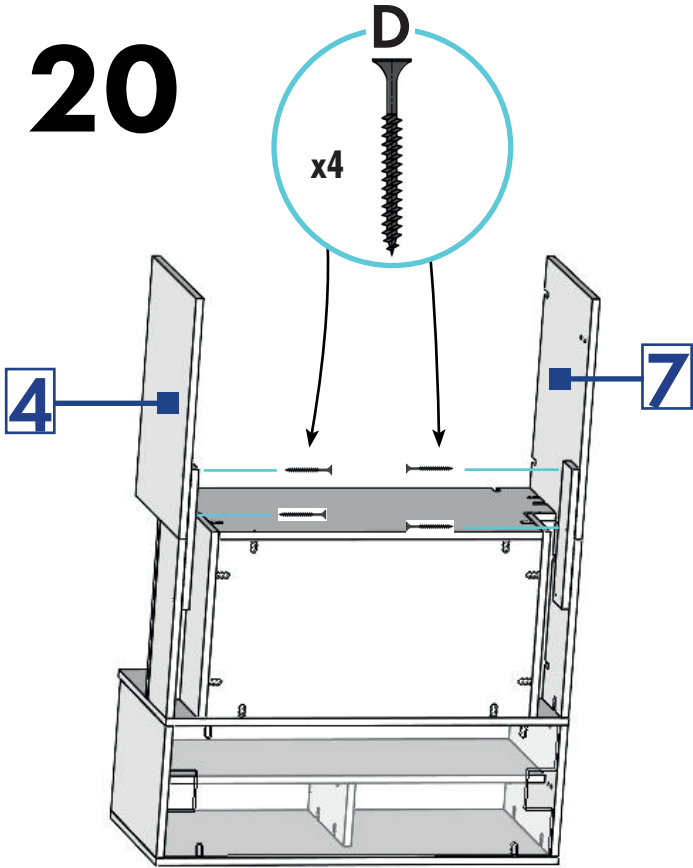

22

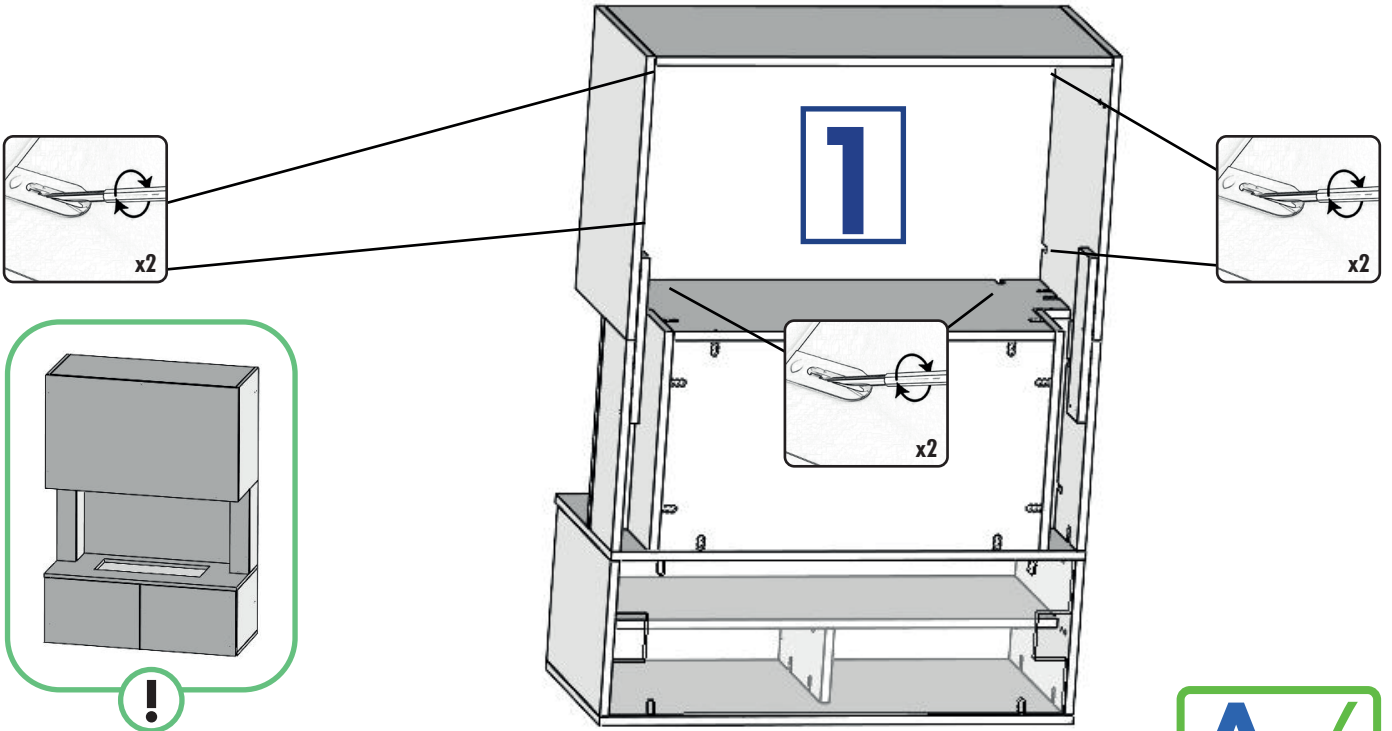

A

2

7

4

x7

x2

x2

x2

!

A ✓

23

B

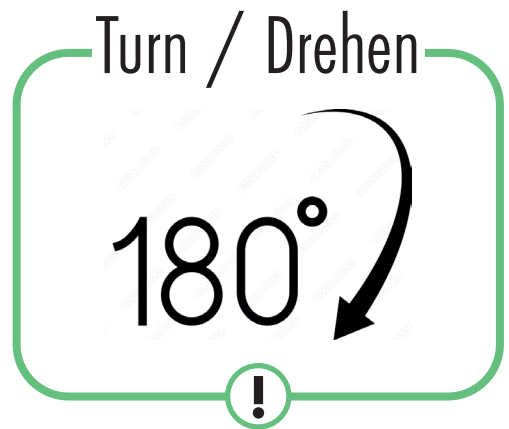
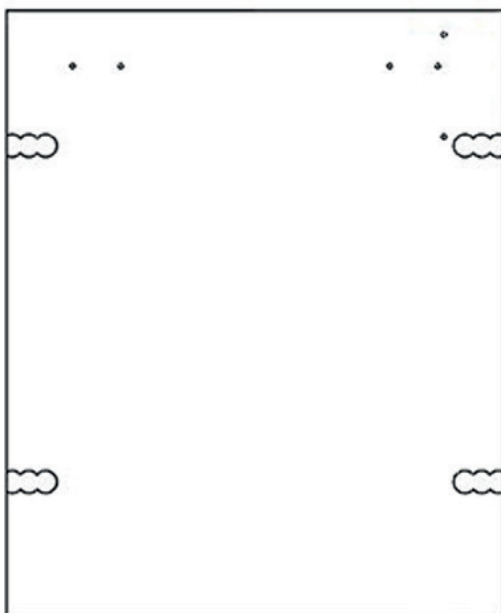
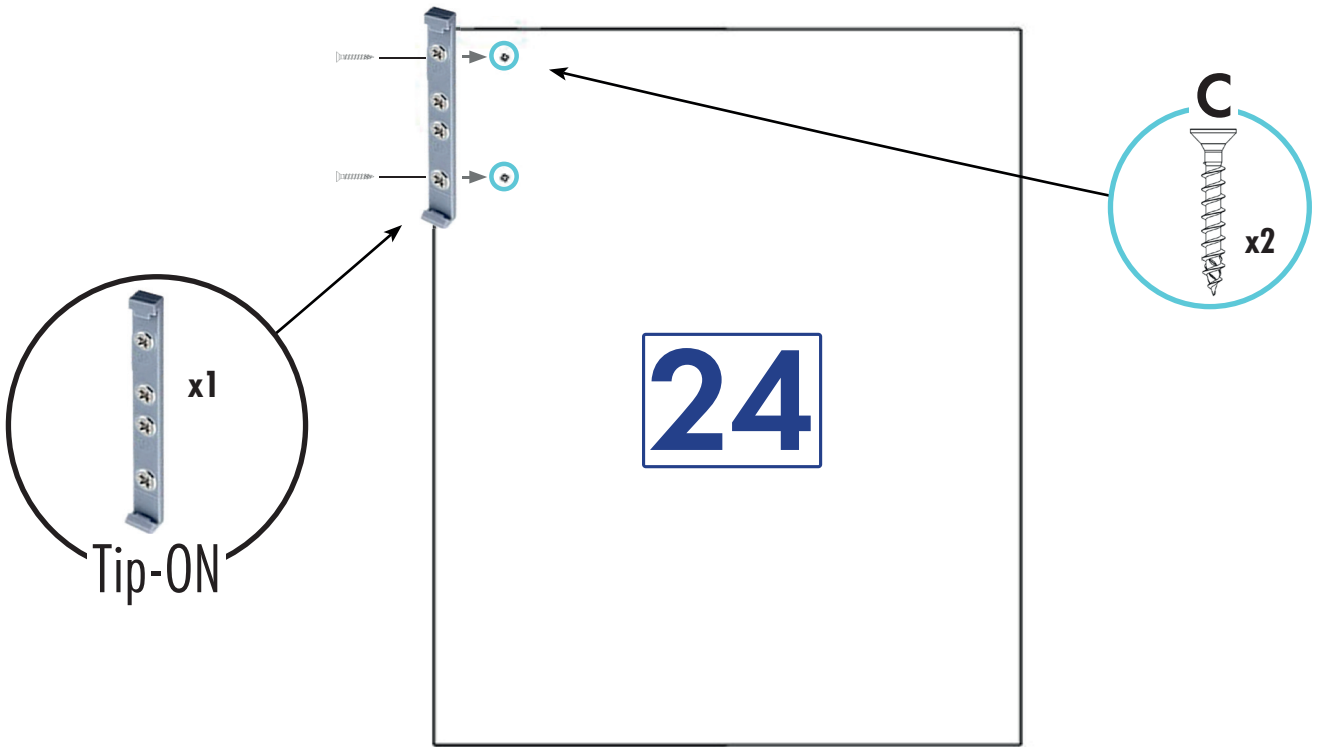

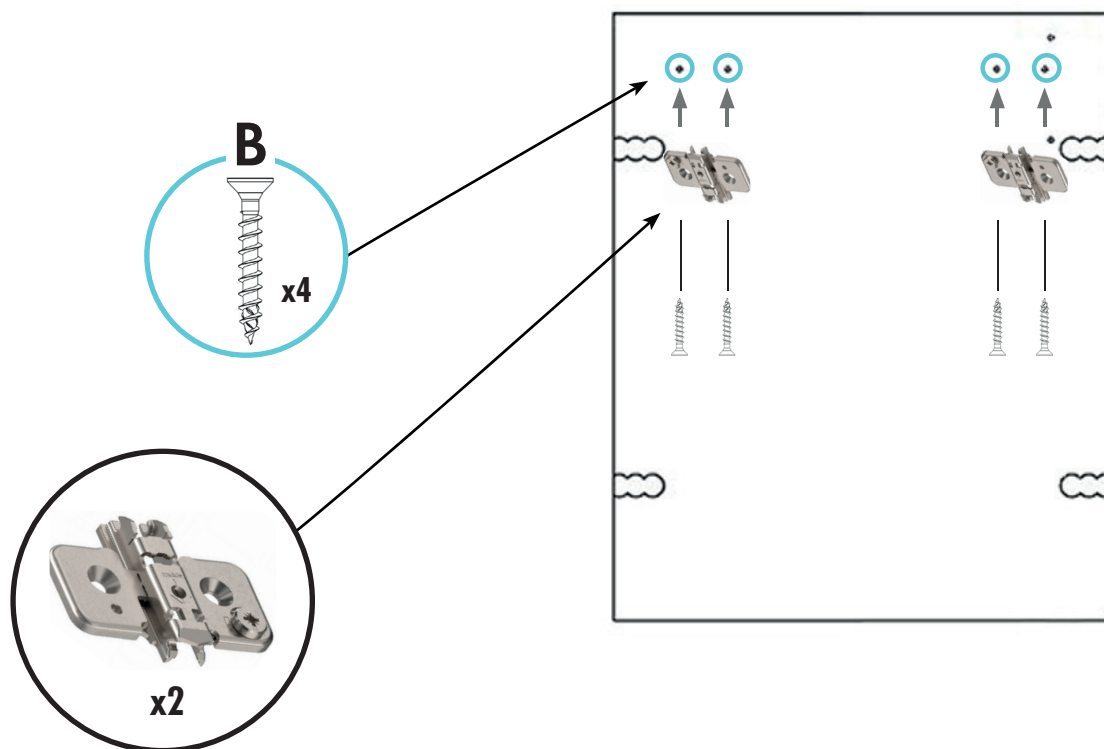

24

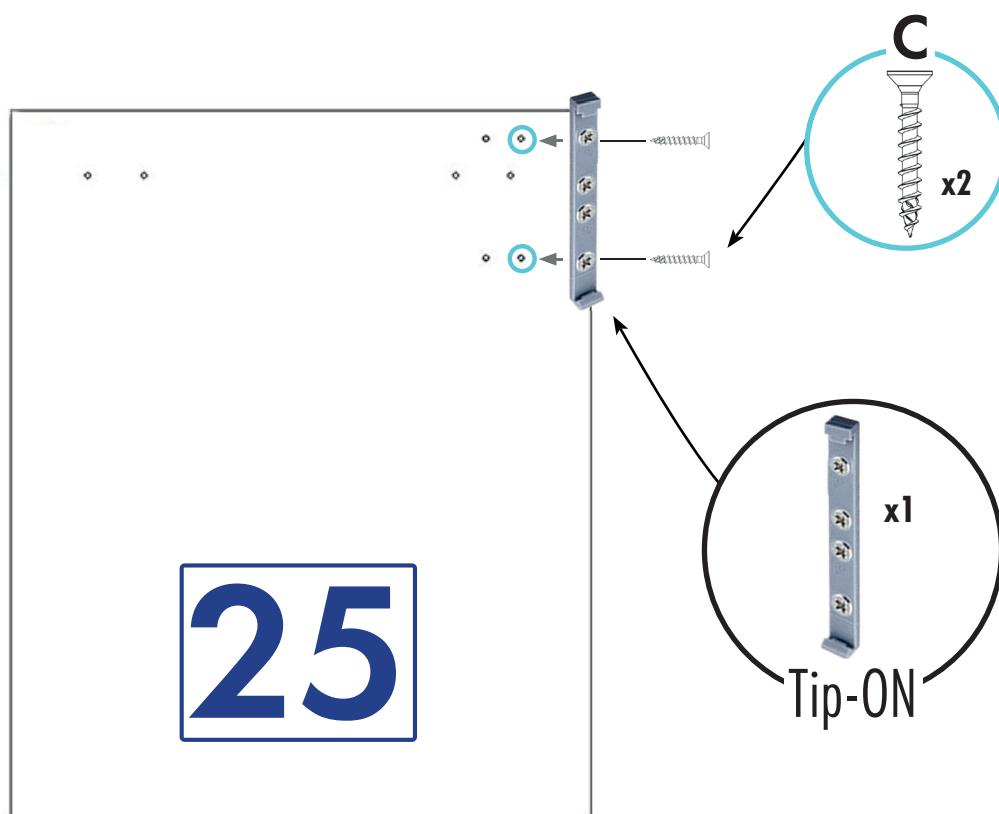

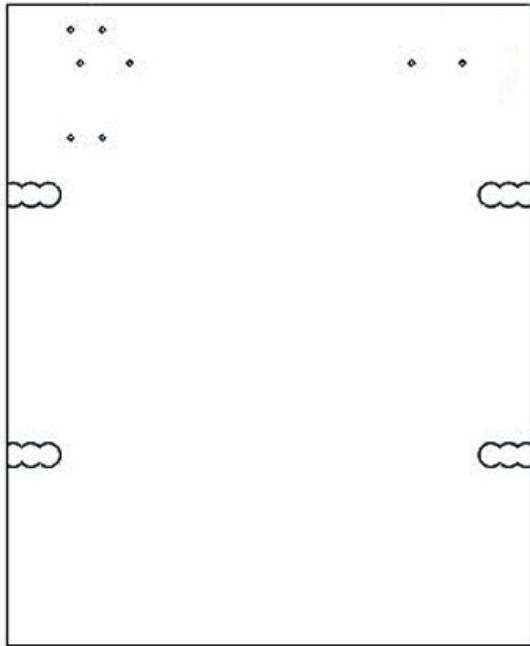

Turn / Drehen
180°
!

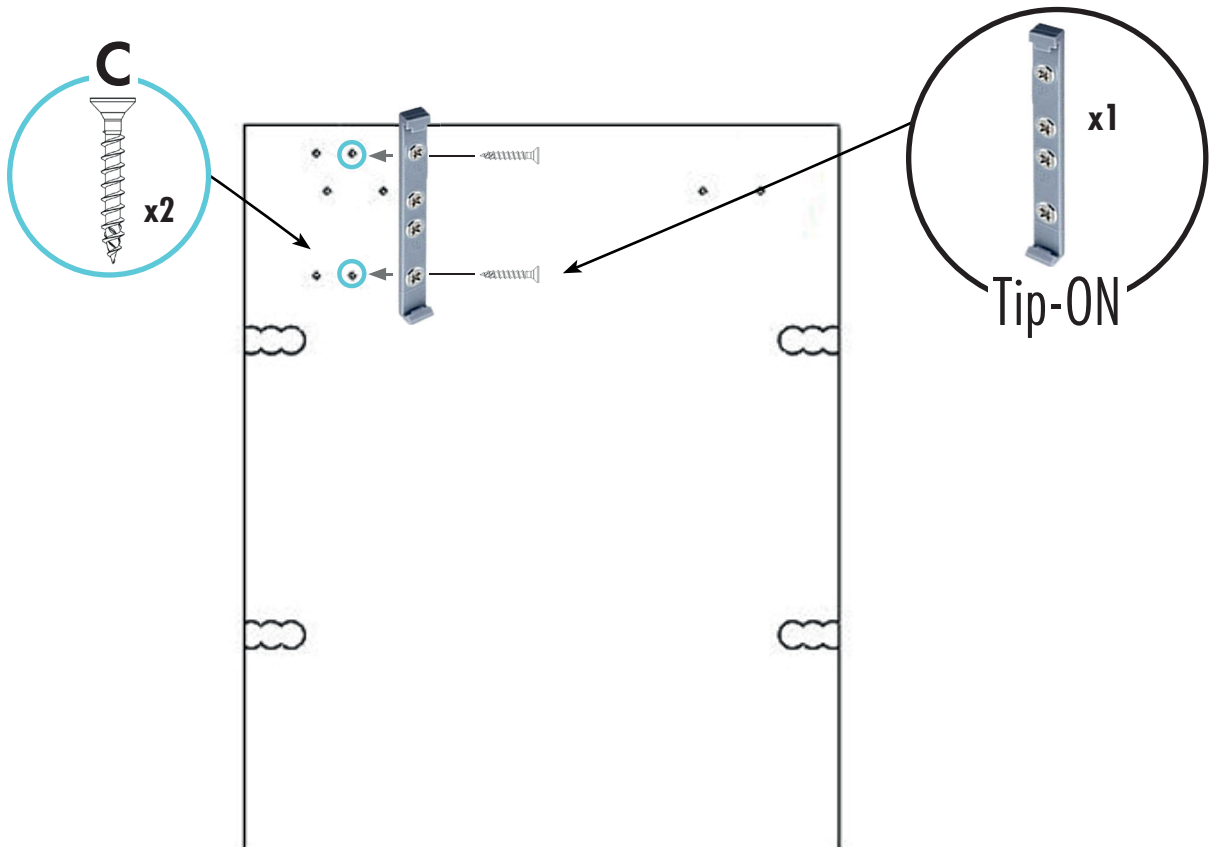

25

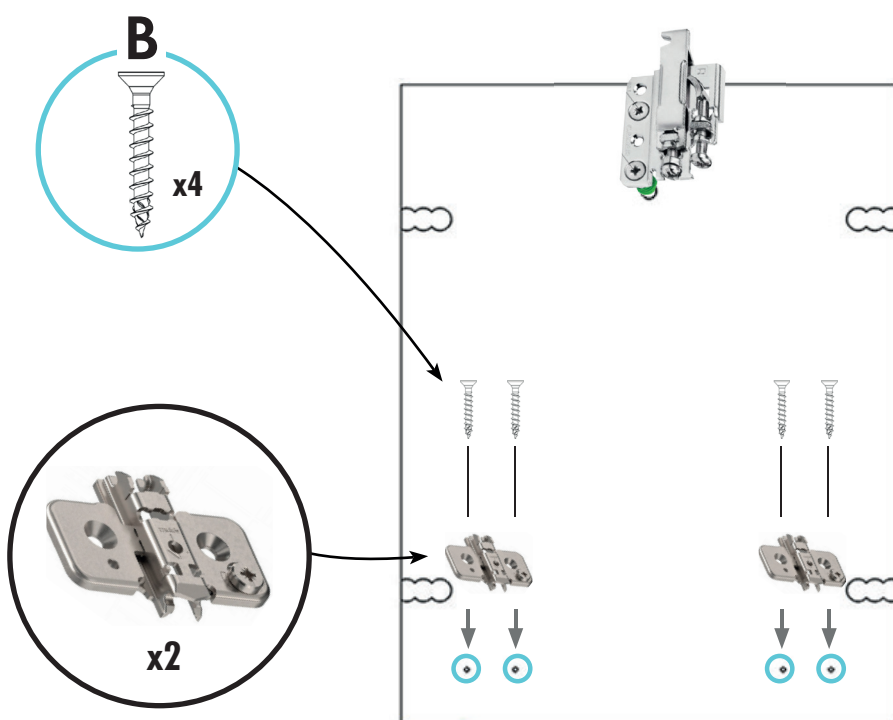
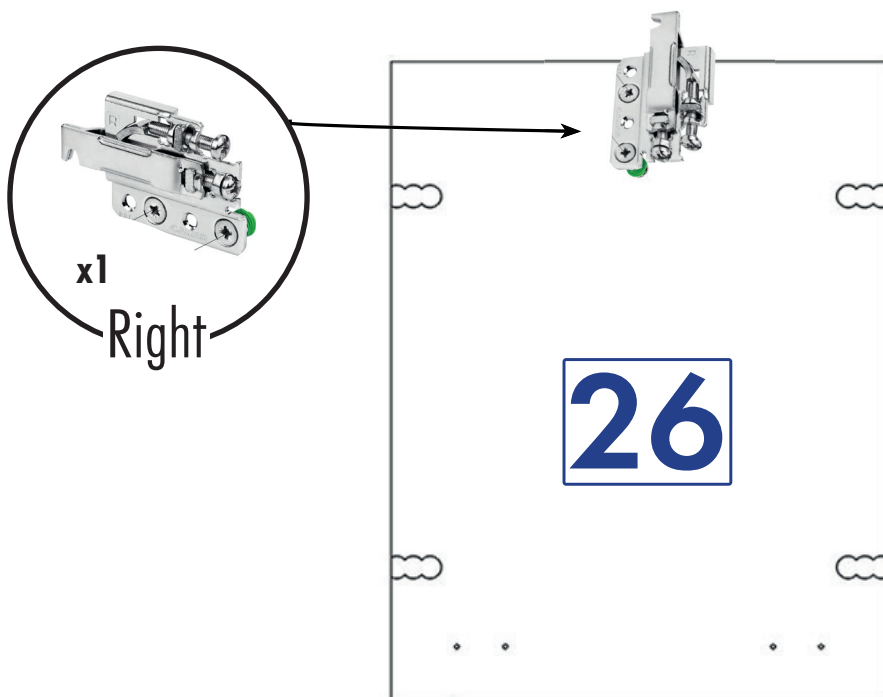

26

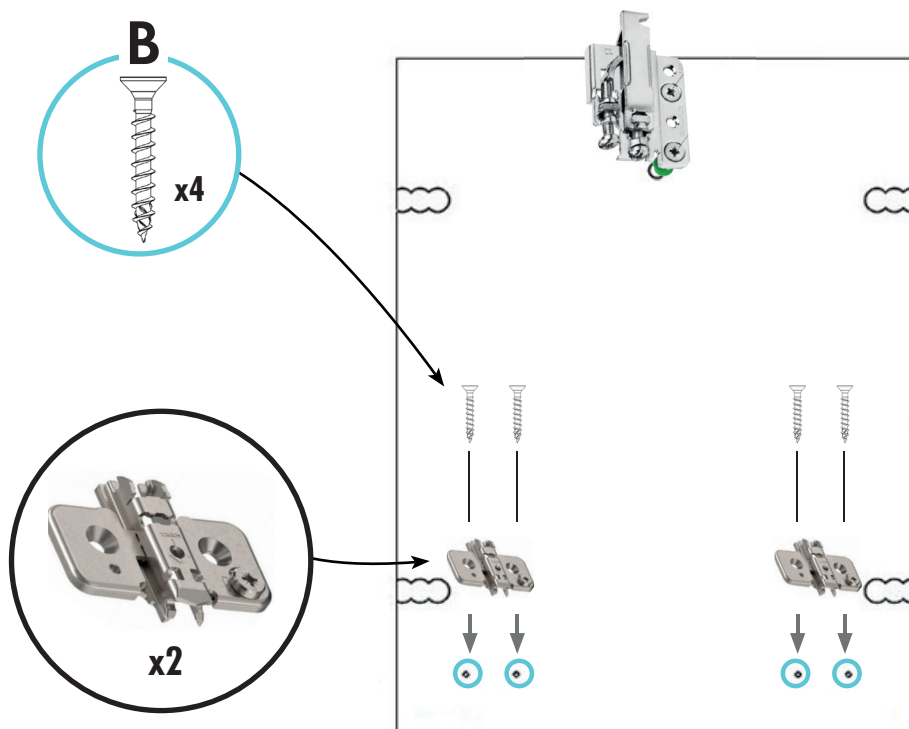
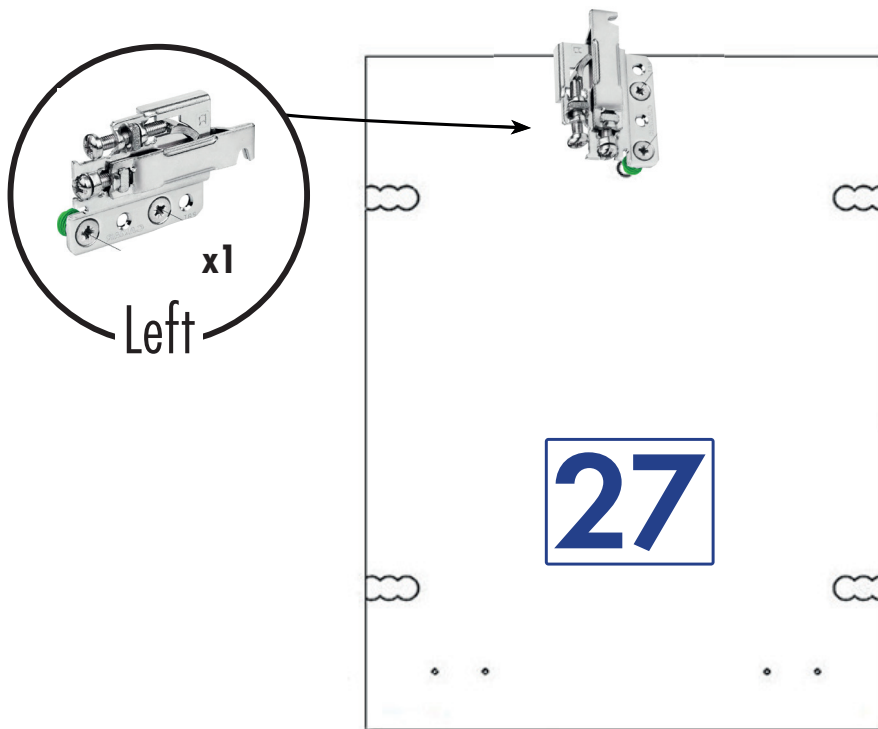
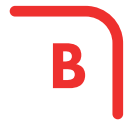

27

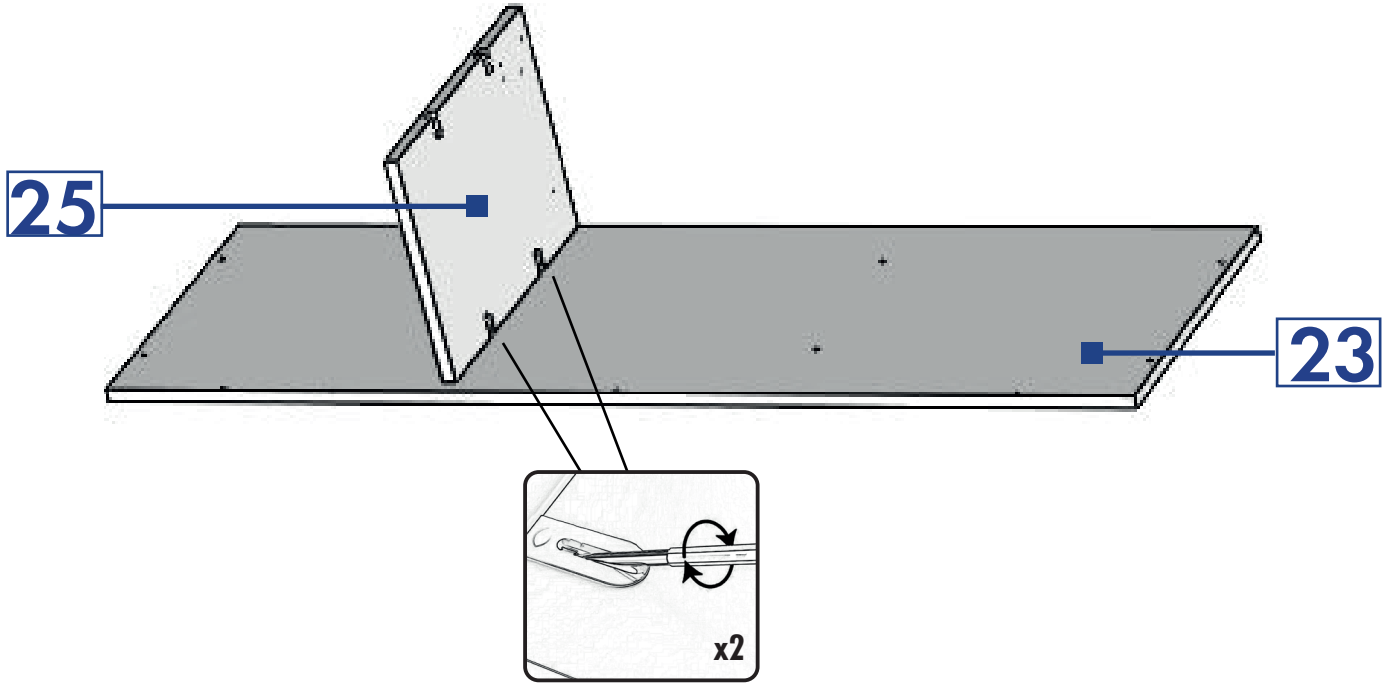
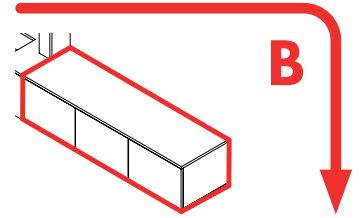

28

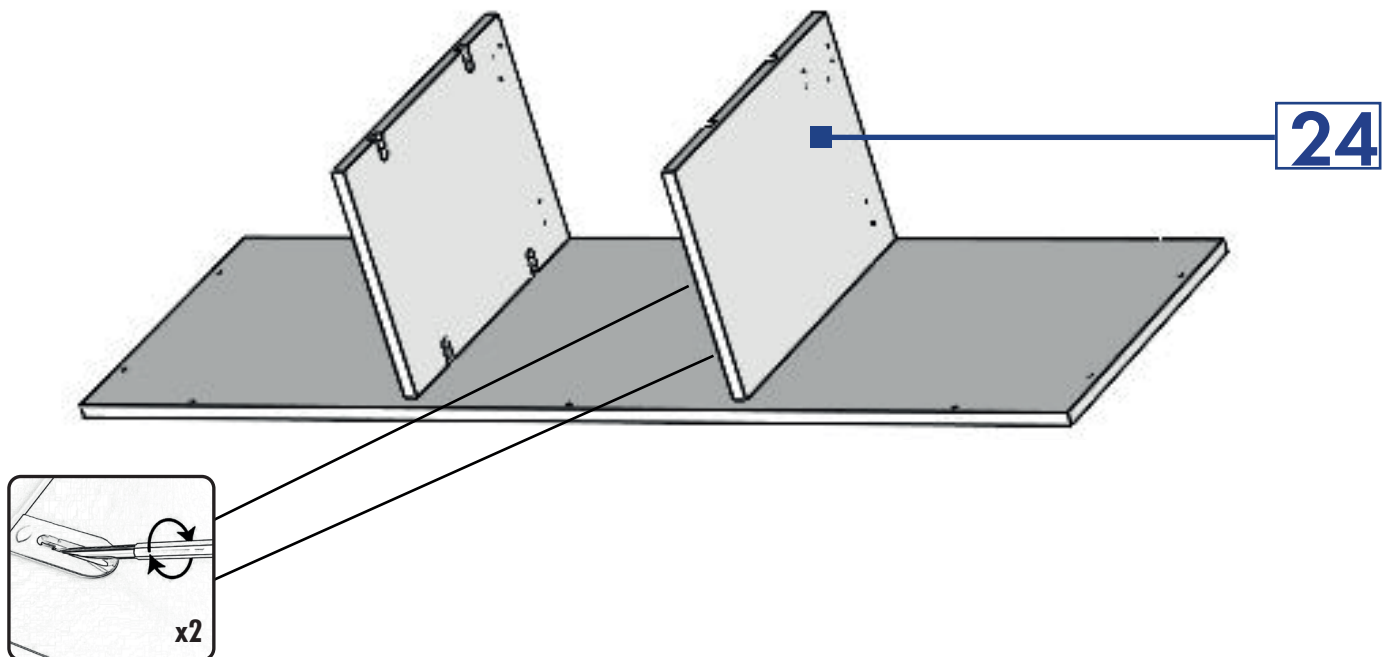

29

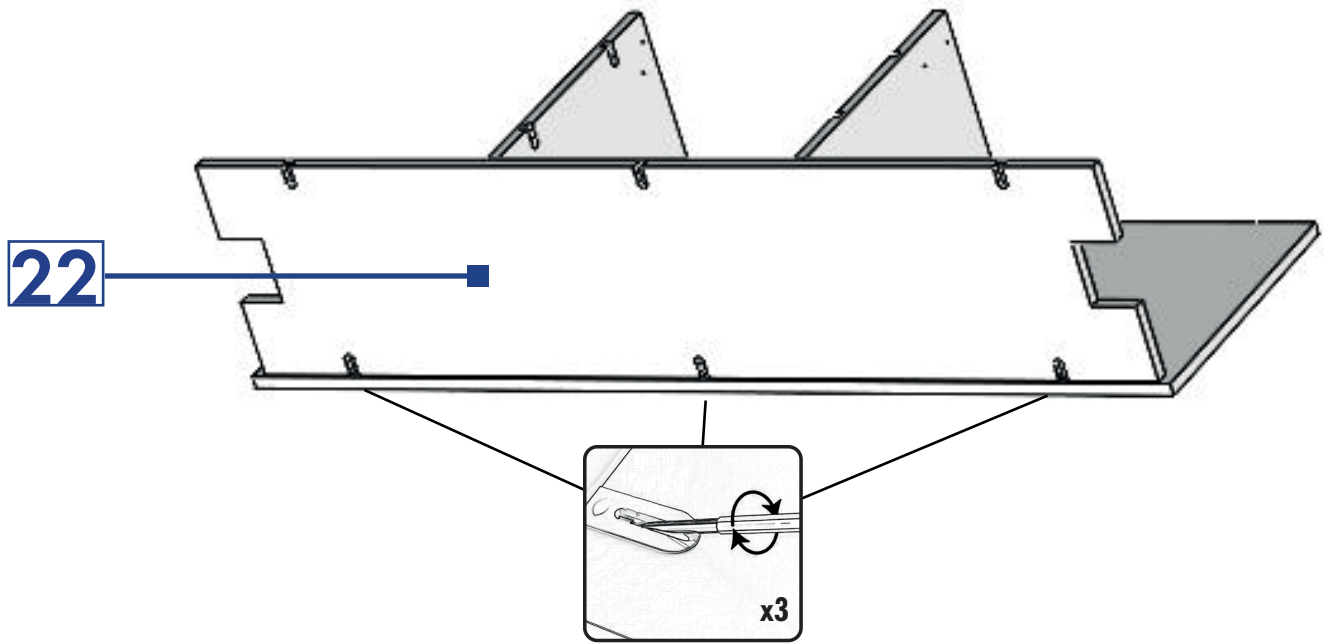

30

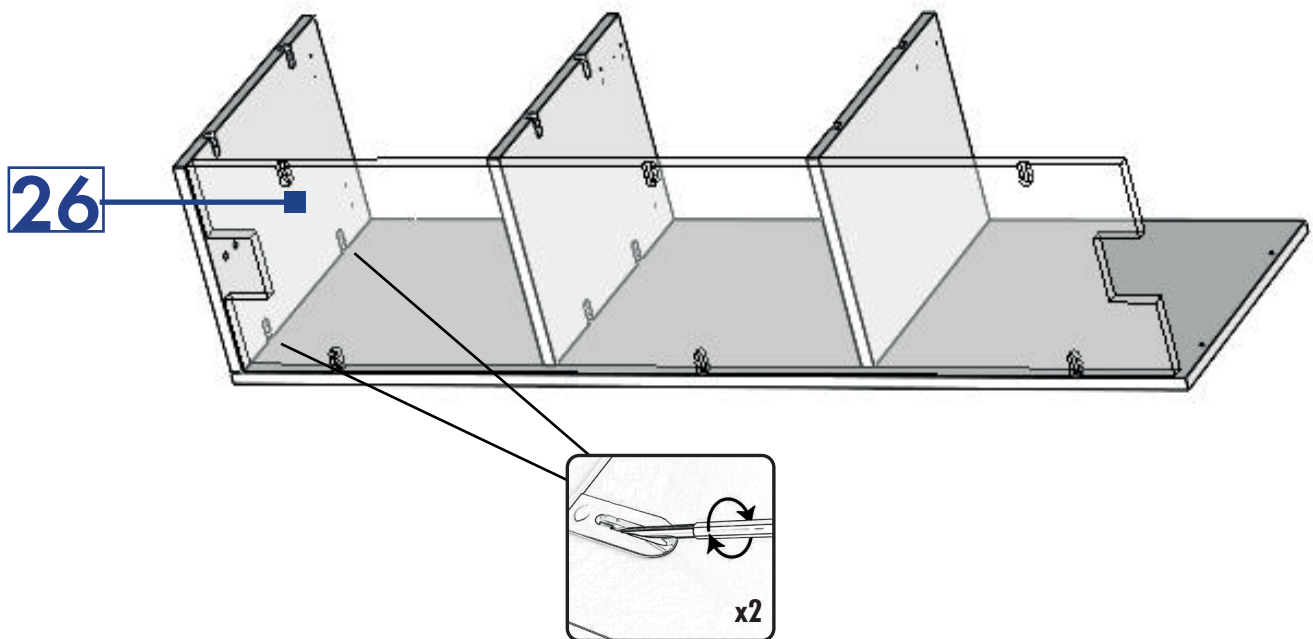

31

B

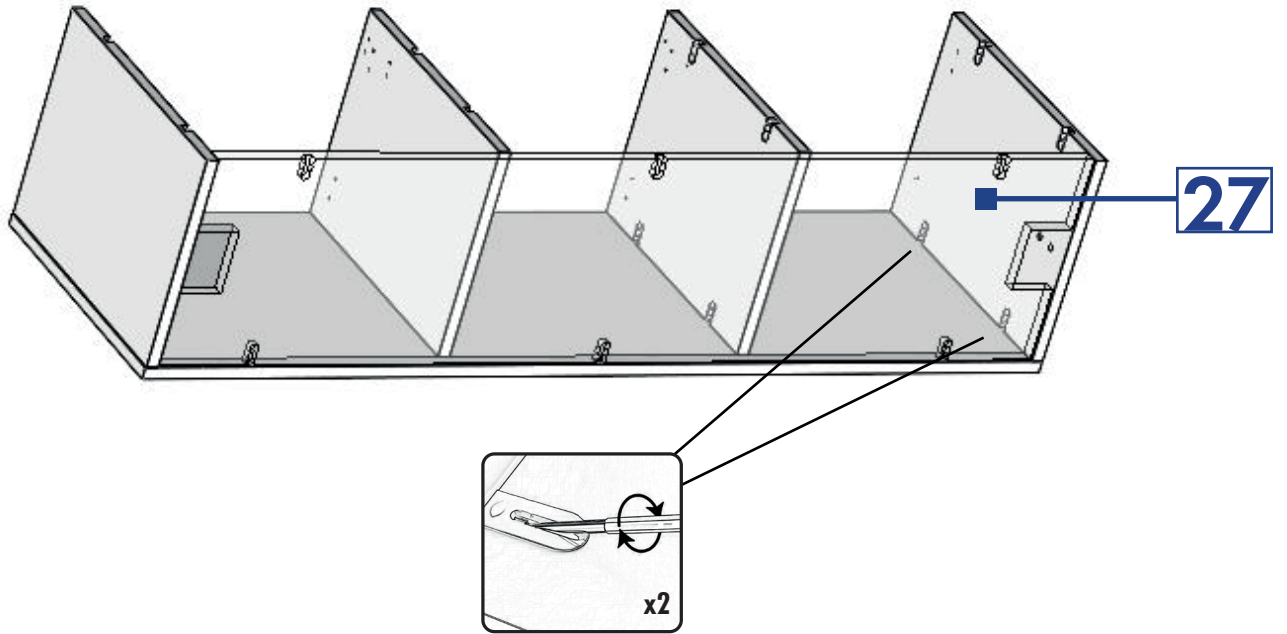

32

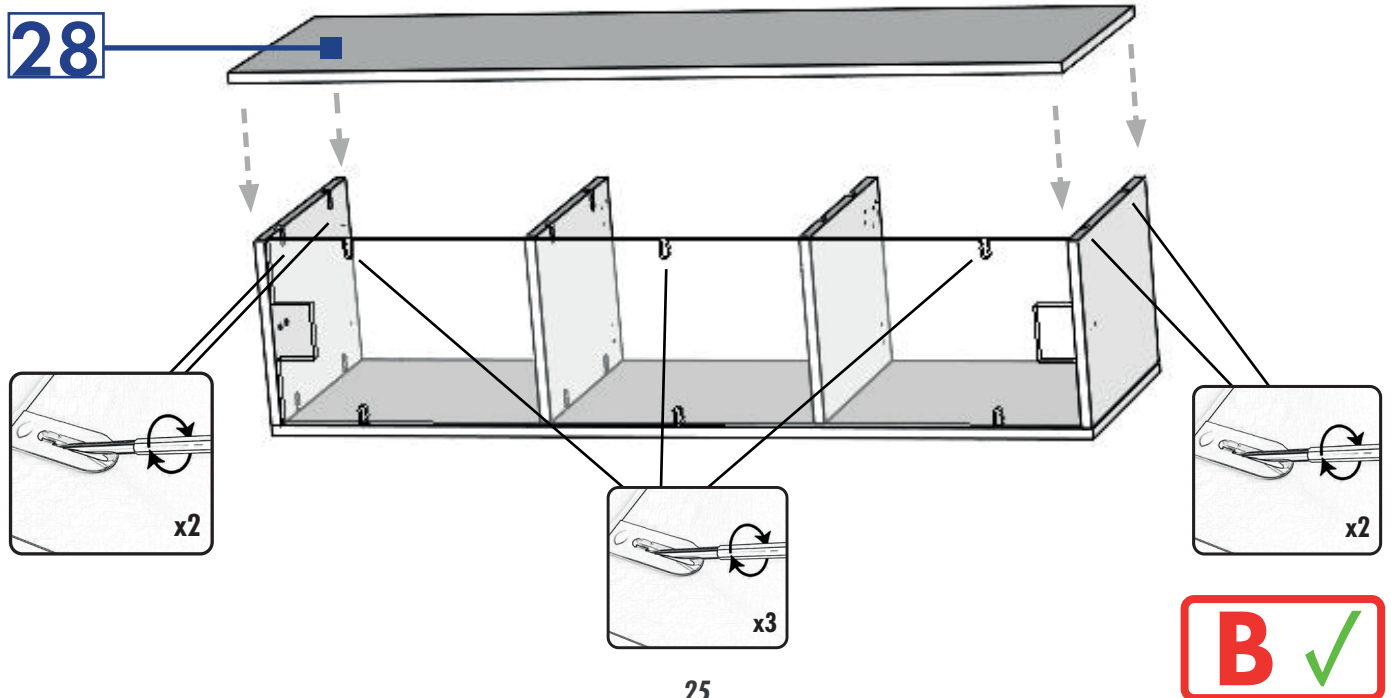

33

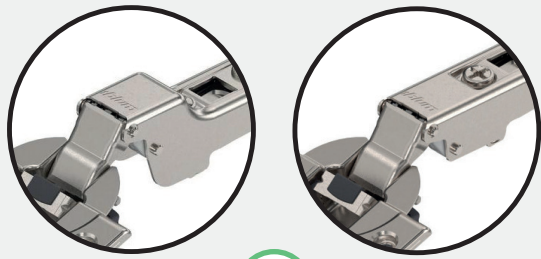

E1000018



E1000019

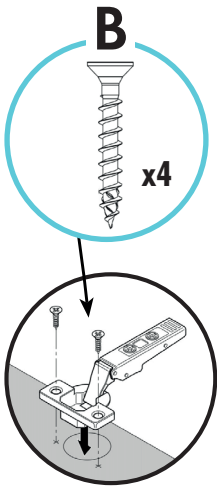

E1000018

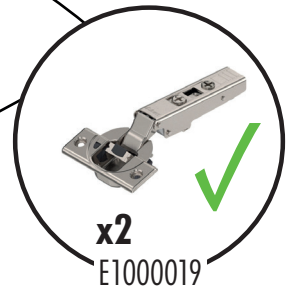

x2
E1000019

34

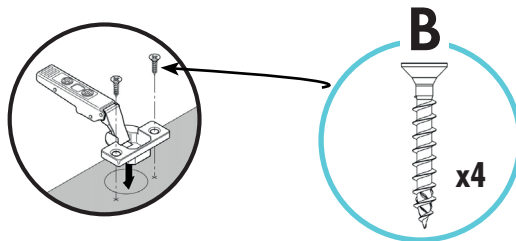

E1000018

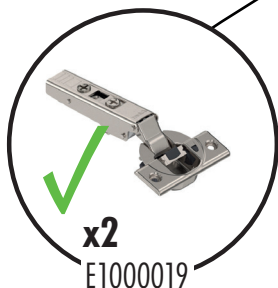

x2
E1000019

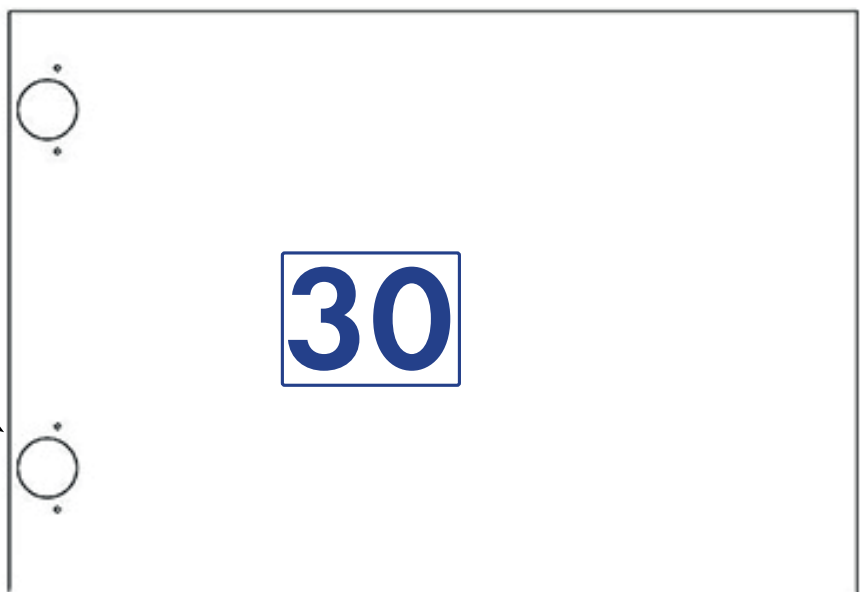

35

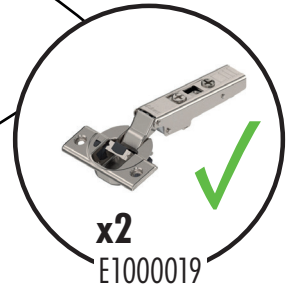
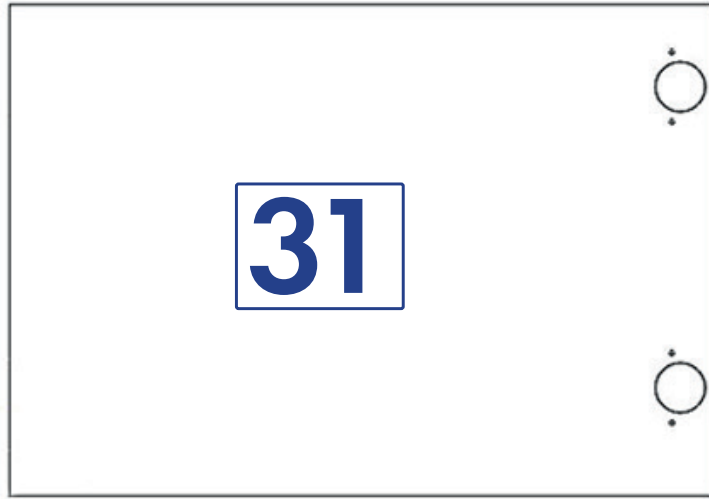
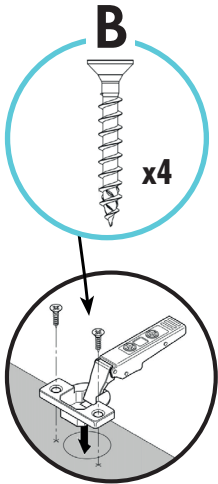

36

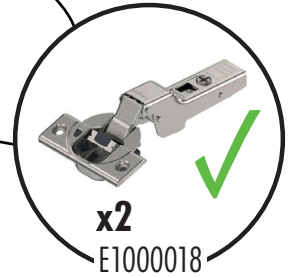
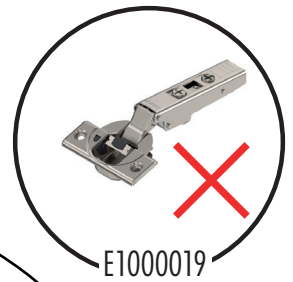
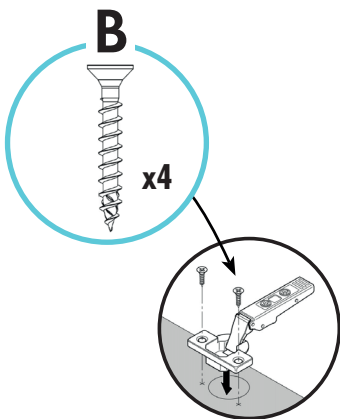

37

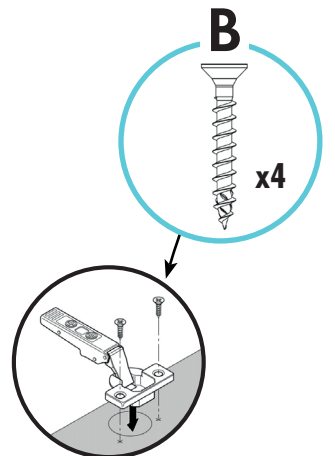
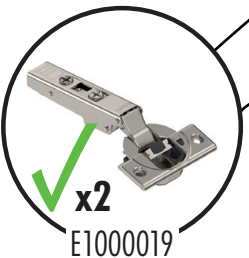

38

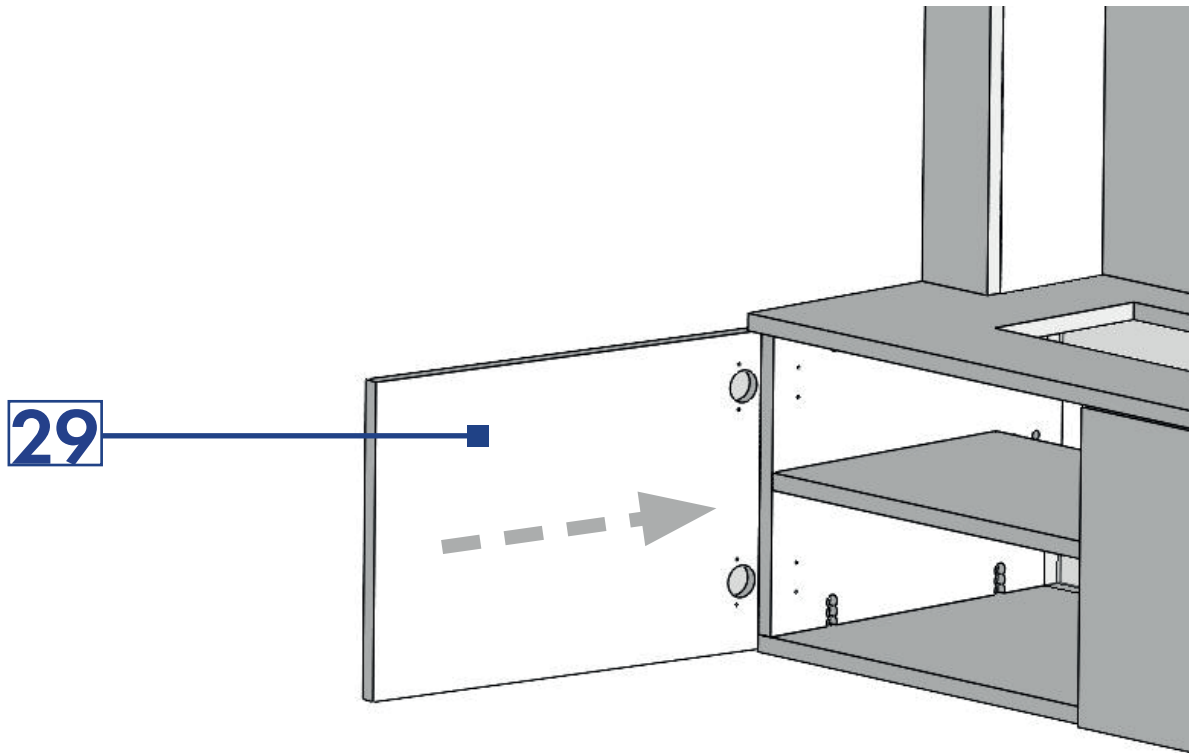

39

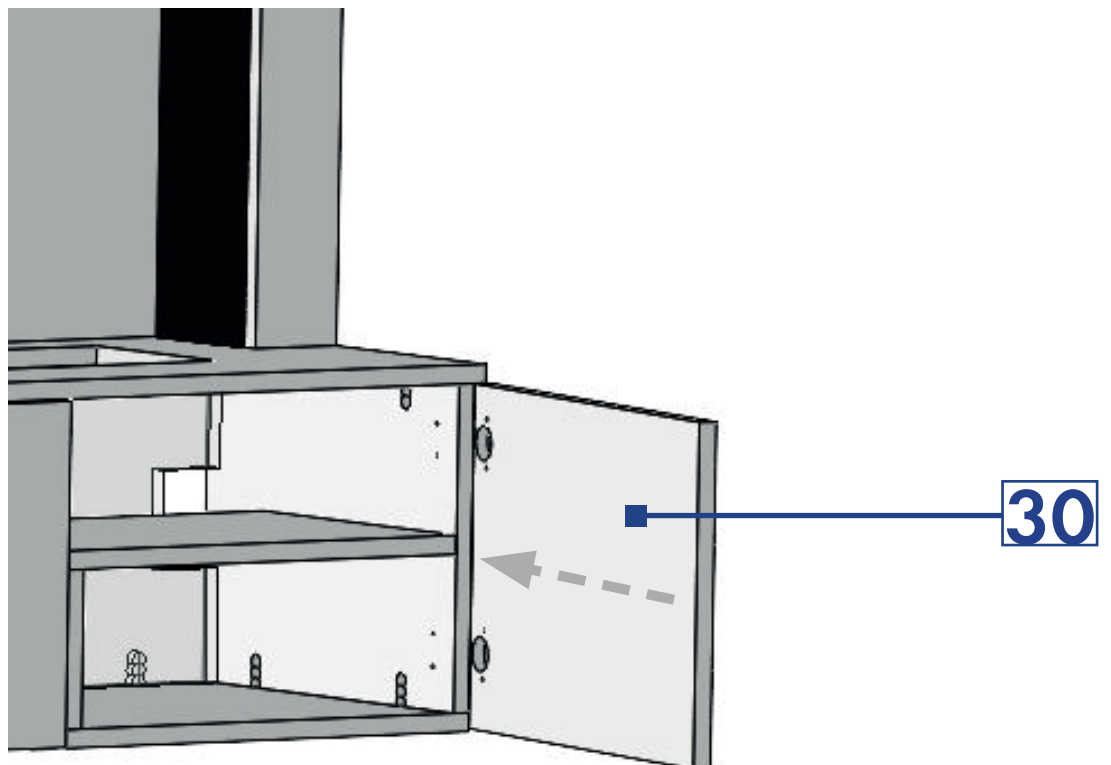

40

B

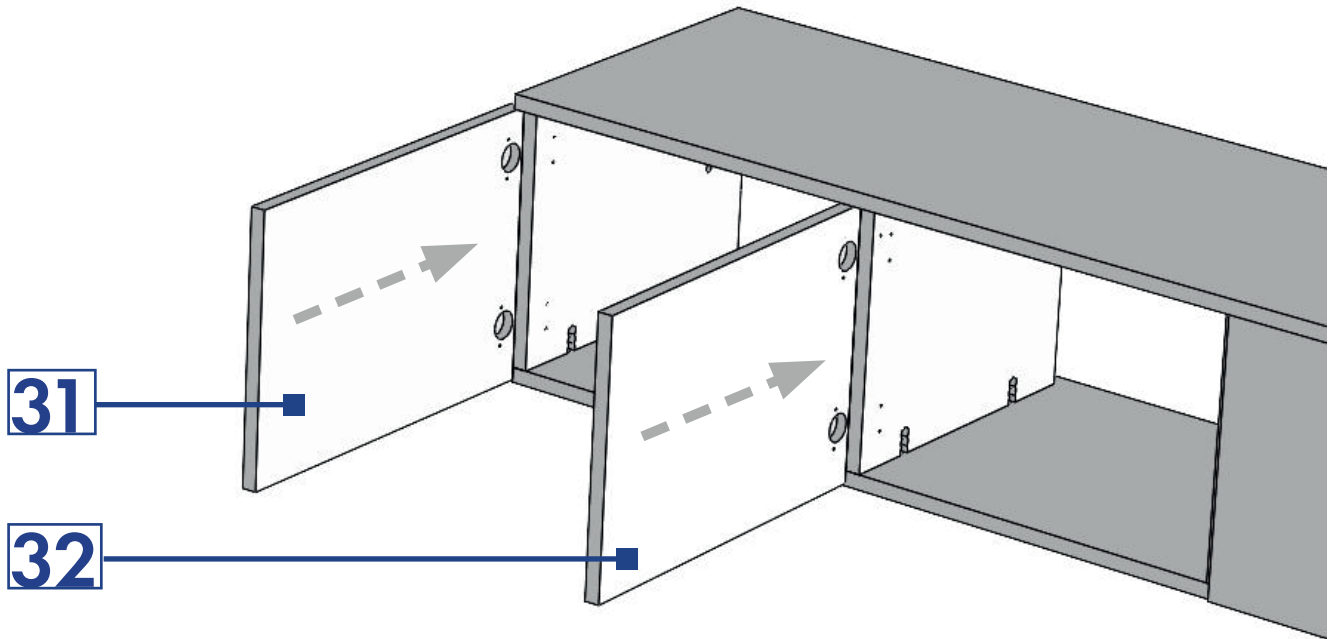

41

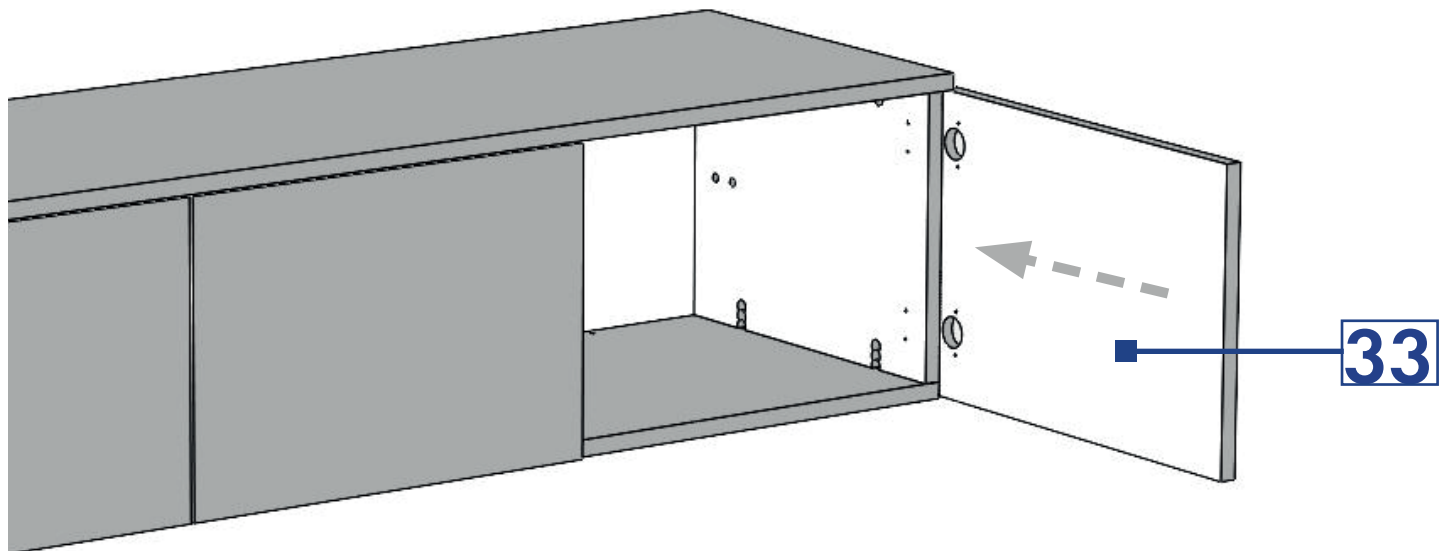

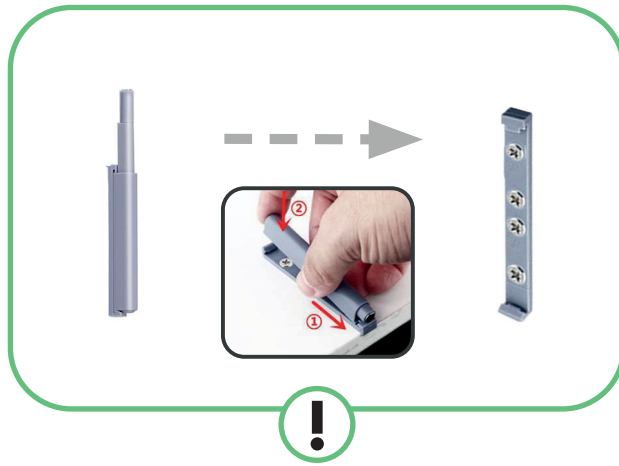

42

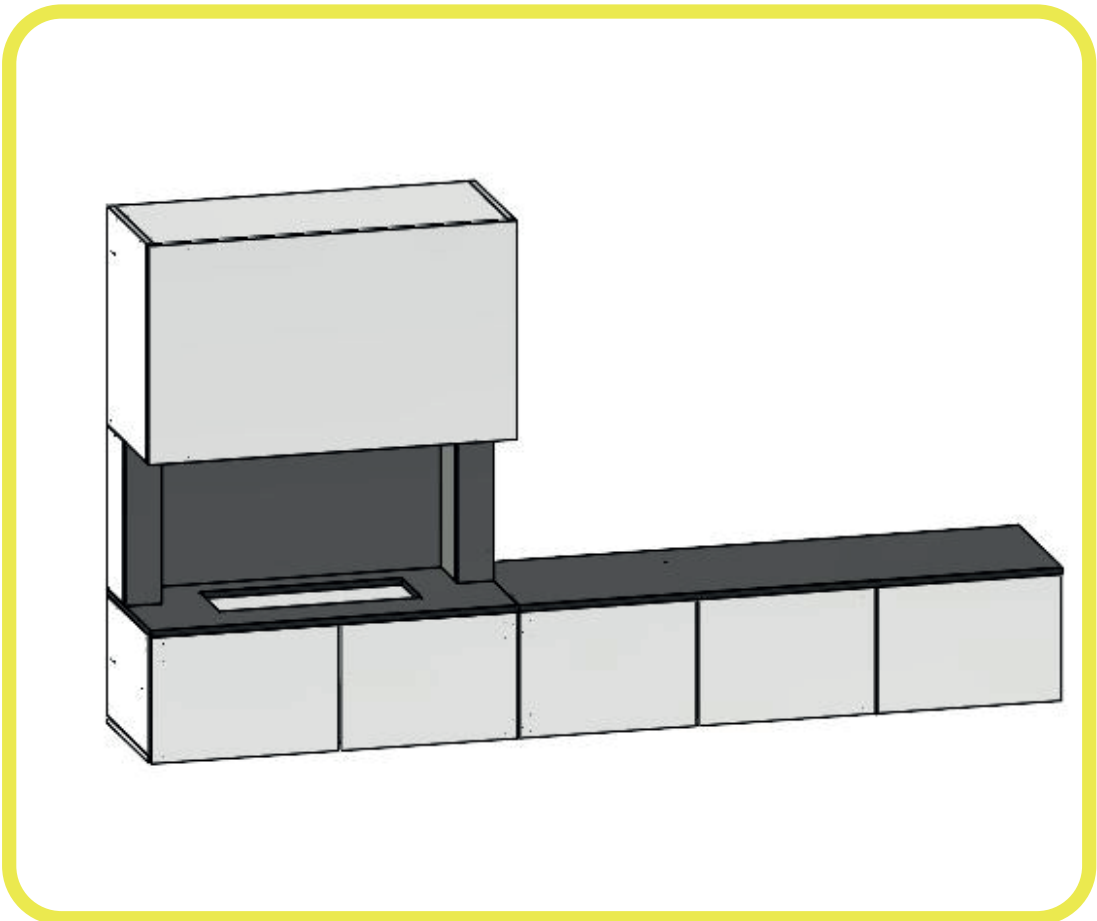



E-Motion 3D

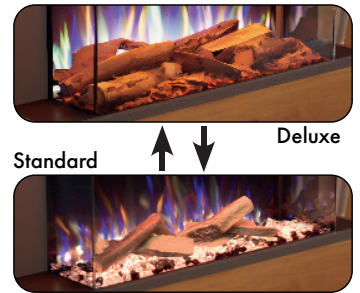
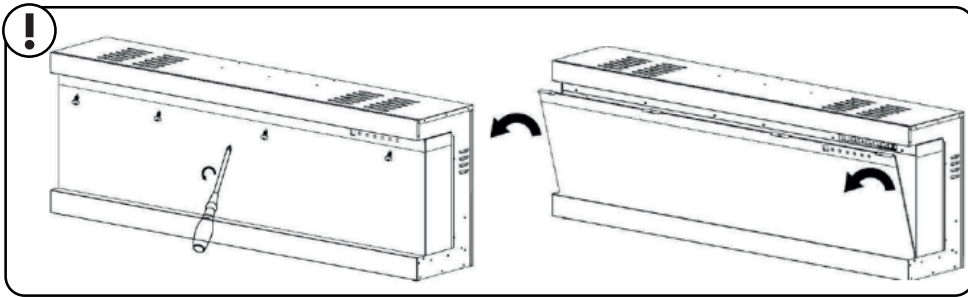
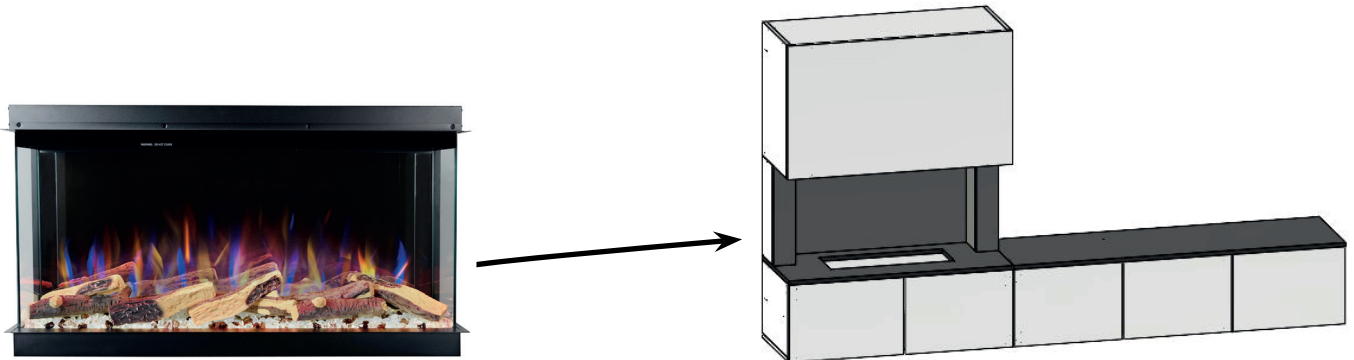

Water Vapour

